

take a breath



AFT FILTER®

PRODUCT CATALOGUE

www.aftfiltre.com.tr



www.aftfiltre.com.tr 



AFT FILTER®

take a breathe



take a breathe



Navy blue; is the symbol of the success and power. We wanted to reflect our success in production in the most effective way with our knowledge and expert staff.



Turquoise; is the color of the Turkishness. It is the most prominent carrier of balance, nature and energy. While producing filtration products; we preferred turquoise considering the importance we give to clean air quality and being sensitive to the environment.



Blue; is the color of the trust, responsibility and honesty. We wanted to make a sense of trust and loyalty, which we want to establish with our customers, within the framework of sincerity, with blue.

And by combining these three colors, all the thoughts we want our brand to make feel, we put it together in the same color.

ABOUT US



- AFT Filter, which founded in 2013 with the motto of “clean environment, breath fresh” and produces various air filtration products for environments where people live intensively, continues to grow and develop its production technologies day by day.
- With it’s modern production facilities and advanced machinery range AFT Filter is proud of being able to deliver quality products to its customers in more than 30 countries in 4 continents in a short time using fast production and advanced logistics network.
- In addition to standard production, AFT Filter, which realizes special projects that require high engineering precision in line with customer requests & demands, with its experienced R&D staff, is frequently mentioned in the field of air filtration and quickly climbs the steps among leading manufacturers who are experts in this field.



OUR MISSION



- Everyone has the right to breathe healthily. Thanks to the filters we produce, each of which passes specific quality control tests, everyone will be able to reach healthy clean air.
- Again, considering the energy costs of ventilation systems, energy efficiency is prioritized thanks to our low pressure filters.

OUR VISION



- To represent our country in the global filtration market with our high quality & competitive products, and to produce more efficient filters in order to increase the air quality for the whole world.



**HVAC AIR
CONDITIONING SYSTEMS**



HOSPITAL & LABORATORIES



COMMERCIAL BUILDINGS



CLEANROOMS



**PHARMACEUTICAL
INDUSTRY**



**FOOD & BEVERAGE
INDUSTRY**



POWER PLANTS



MICROELECTRONICS



**SPACE AVIATION
INDUSTRY**



- WHAT IS THE FILTRATION ?..... 10
- EN 779:2012 STANDARD..... 10
- HOW DO FILTERS COLLECT THE PARTICLES ?..... 11
- ISO 16890 STANDARD..... 12
- EFFICIENCY TABLE ACCORDING TO ISO 16890..... 12
- COMPARISON OF EN 779:2012 & ISO 16890 STANDARDS..... 13
- EN 1822 STANDARD..... 14
- SELECTING THE IDEAL AIR FILTER..... 15
- MERV RATING FOR AIR FILTERS..... 16
- CLASS SELECTION ACCORDING TO ISO 16890..... 17
- SUPPLY AIR CLASSIFICATION..... 17
- COARSE PRE FILTERS..... 19
 - FILTER ROLL & PADS..... 20
 - G3 / G4 SYNTHETIC PET MEDIA ROLLS..... 21
 - PAINT STOP / GLASS FIBRE ROLLS..... 21
 - ACTIVATED CARBON IMPEGRATED POLYESTER FILTER MEDIA ROLLS..... 22
 - M5 CEILING FILTER MEDIA ROLLS 22
 - POLYURETHANE SPONGE FILTER PAD..... 22
 - PANEL FILTERS..... 23
 - Z TYPE
 - Z TYPE PET 24
 - Z TYPE POL..... 25
 - Z TYPE CARDBOARD..... 26
 - FLAT TYPE..... 27
 - METAL (KITCHEN HOOD)..... 28
 - BAG FILTERS..... 29
 - G3 BAG FILTERS..... 29
 - G4 BAG FILTERS..... 29
- MEDIUM & FINE FILTERS..... 31
 - BAG FILTERS..... 32
 - M5-M6 BAG FILTERS..... 33
 - F7-F8 BAG FILTERS..... 34
 - PANEL FILTERS..... 35
 - PLASTIC FRAME..... 36
 - GALVANIZED FRAME..... 37
 - HEADER TYPE PANEL FILTERS..... 38
 - V COMPACT FILTERS..... 39
 - STD SERIES..... 40
 - PRO SERIES..... 40
 - V BANK FILTERS..... 41
- EPA & HEPA ULPA FILTERS..... 43
 - HEPA TERMINAL FILTERS..... 44
 - MDF (WOODEN FRAME).....
 - 78 MM DEPTH..... 45
 - 149 MM DEPTH..... 46
 - ALUMINIUM FRAME
 - 69 MM DEPTH..... 47
 - 78 MM DEPTH..... 48
 - 80 MM DEPTH WITH GEL SEAL..... 49
 - 149 MM DEPT 50
 - HIGH FLOW FILTERS 292 MM..... 51
 - MDF (WOODEN) FRAME..... 52
 - ALUMINIUM FRAME..... 53
 - GALVANISED STEEL FRAME..... 54
 - V COMPACT FILTERS..... 55
 - V BANK FILTERS..... 57
 - HOODED TYPE FILTERS..... 59
- GAS (ODOUR) FILTRATION..... 63
 - PANEL FILTERS..... 64
 - Z TYPE AC PANEL FILTER 65
 - GRANULAR AC FILLED PANEL FILTER..... 65
 - V COMPACT FILTER..... 66
 - AC CYLINDER CARTRIDGE FILTERS..... 67
 - AC CYLINDER CARTRIDGE SET 67
 - AC CYLINDER CARTRIDGE..... 67
- FILTRATION EQUIPMENTS..... 69
 - FAN FILTER UNITS..... 70
 - HEPA TERMINAL BOXES FAN FILTER..... 71
 - FILTER FRAMES / HOUSINGS..... 72

take a breathe



AFT FILTER®

take a breathe



breathe

WHAT IS THE FILTRATION ?



For a healthy and comfortable life, the air we breathe must first be clean and of good quality. The air we breathe also contains matter particles and gases formed as a result of people, nature and industrial processes. These particles and gases negatively affect our quality of life and health by reducing the quality of the air we breathe. The vast majority of these harmful particles in the air are too small to be seen. In order not to be exposed to these particles, it is very important for our health to clean the air to be inhaled with a special filter. Especially in areas such as hospitals, laboratories, factories, operating rooms, HVAC systems, filtering is very important. The following situations may occur in environments that are not filtered.

- Diseases caused by poor indoor air quality (Legionnaires' Disease, Asthma)
- Reproduction of microorganisms and increased risk of infection (Bacteria and viruses are carried by dust)
- Deterioration and noisy operation of devices in ventilation systems
- The ventilation ducts become dirty and it is difficult to provide clean indoor air

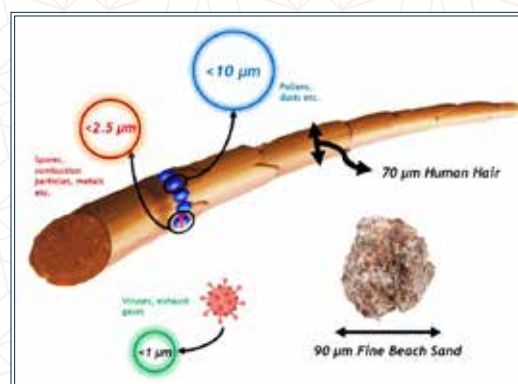

EN 779:2012 STANDARD



EN779: 2012 is efficiency standard for dust filters.

In this standard, classification is made based on particles of 0.4 micron size. Initial efficiency must be below 98% for the implementation of the EN779: 2012 standard. Testing is done between 0.24 m³/s and 1.50 m³/s air flow rates.

If the filter's average efficiency is less than 40%, it is classified as class G, if it is between the 40% 80%, it is classified class M, if it is more than 80%, it is classified class F. Class G is grouped within itself while average arrestance is based on, while class M and class F are based on average efficiency.

According to the EN779: 2012 standard, filters are divided into three different efficiency groups; coarse, medium and fine.

Filter Group	Filter Class	Avg. Arrestance of Synthetic Dust (Am) %	Avg. Efficiency for 0.4 µm particles(Em) %	Min. Efficiency for 0.4 µm particles (Em) %	Final Pressure Drop (Pa)
COARSE	G1	50≤Am<65	-	-	250
	G2	65≤Am<80	-	-	250
	G3	80≤Am<90	-	-	250
	G4	90≤Am	-	-	250
MEDIUM	M5	-	40≤Em<60	-	450
	M6	-	60≤Em<80	-	450
FINE	F7	-	80≤Em<90	35	450
	F8	-	90≤Em<95	55	450
	F9	-	95≤Em	70	450

HOW DO FILTERS COLLECT THE PARTICLES ?



There are 5 different ways to particle collection mechanisms. These are;

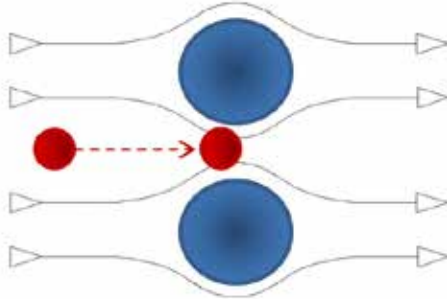

1.) Straining Effect

Straining effect is the most simple mechanism in particle collection mechanisms. This effect is related with media density, media spacing and the size of the particle. When the particle diameter is bigger than the opening between the filter media's members, they can't leak and they are captured between the filter media's members.

2.) Inertia Effect

Particles at a certain velocity tend to remain at that velocity and travel in a continuous direction. Particles drifting in the air flow can't rotate around the filter media's member because of their inertia and the particles are captured by the filter media's members. This effect increase in high air flow velocity and high particle sizes.

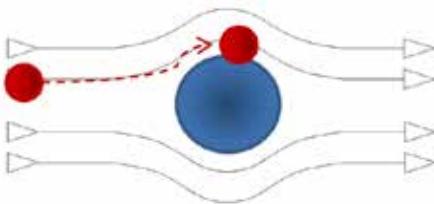
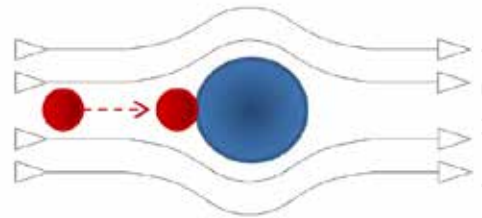

3.) Interception Effect

When the particle size is too small, the particle follows an orbit around the filter media members. If the particle passes to the filter media's member closer than its radius, it is captured by the filter media's members.

4.) Diffusion Effect

When the particle size is under the 1 micron, the particles collision with gas molecules and they begin random moving (Brownian). As a result of this movement the particles are captured by filter media's members. This effect decrease in low air flow and the particle sizes.

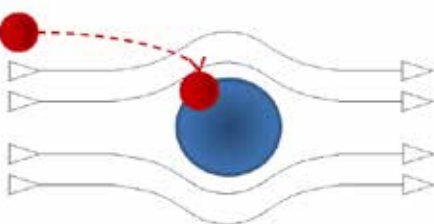
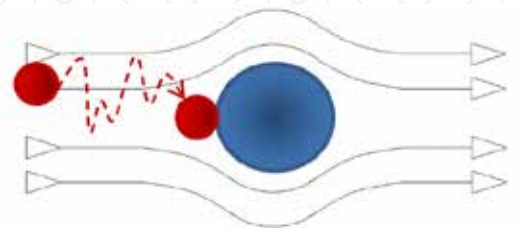

5.) Electrostatic Effect

The particles occupy the charged areas on the filter media members and neutralize their electrostatic charges. Thus particles are captured.



Filter Fibre



Particle

---> Particle Path



Airflow

ISO 16890 STANDARD



The ISO 16890 standard was published in 2016 in order to make more accurate choices in filter choices, to reduce the filtration costs with the use of the correct filter, to reduce energy expenditure and to clean the ambient air.

Filters are classified according to particle sizes according to ISO 16890 standard. The particle sizes based on are 10 micron, 2.5 micron and 1 micron. According to these particle sizes, ePM values were created. Classification is made according to ePM values and rates.

Classes according to ISO 16890 are as follows.

- ISO Coarse
- ISO ePM10
- ISO ePM2,5
- ISO ePM1

ISO Coarse: It is a classification group used for filters that can hold particles of 10 microns and above at a rate below 50%.

ISO ePM10: Classification group used for filters that can hold particles of 10 microns and above at a rate of 50% and above.

ISO ePM2,5: It is the classification group used for filters that can hold particles 2.5 microns and above at a rate of 50% and above.

ISO ePM1: Classification group used for filters that can hold particles 1

CLASS	MIN. EFFICIENCY	PARTICULAR MATTER TYPE
ISO Coarse	10 μm \leq 50%	Hair, sand
ISO ePM10	10 μm \geq 50%	Pollen, dust
ISO ePM2.5	2.5 μm \geq 50%	Spores, bacteria, pollens
ISO ePM1	1 μm \geq 50%	Exhaust gases, viruses

EFFICIENCY TABLE ACCORDING TO ISO 16890



CLASS	ISO ePM1	ISO ePM2.5	ISO ePM10	ISO Coarse
G3	-	-	-	> 80%
G4	-	-	-	> 90%
M5	-	-	> 50%	-
M6	-	50-60 %	> 60%	-
F7	50-60 %	65-80 %	> 85%	-
F8	65-80 %	> 80%	> 90%	-
F9	> 80%	> 95%	> 95%	-

COMPARISON OF EN779:2012 & ISO 16890 STANDARDS



Until the end of 2016, while the filters were classified according to EN779: 2012 standard, ISO16890 standard has been published since the end of 2016. The transition from EN779: 2012 to ISO16890 standard was completed in mid 2018.

According to the EN779: 2012 standard, filters are classified with reference to 0.4 μm size particles. Choices made according to filters classified by a single particle size

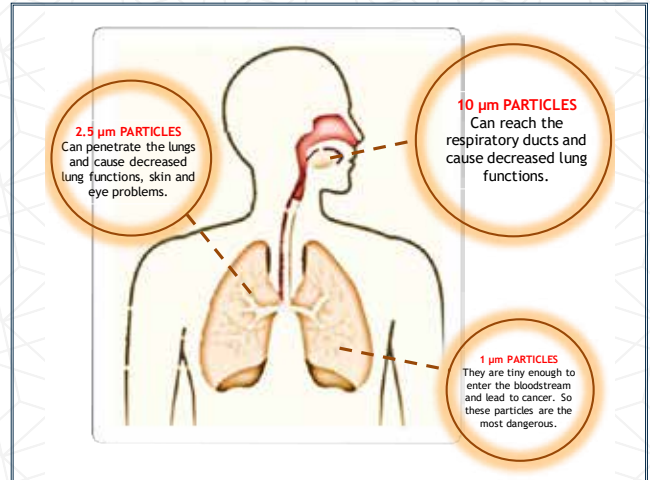

are not sufficient in applications. It is also not sufficient on energy consumption. Therefore, the ISO16890 standard, a more detailed standard for particles ranging from 0.3 μm to 10 μm , has been published.

EN779: 2012 standard gives more theoretical, ISO16890 standard gives more realistic values.

EN779:2012 STANDARD	ISO 16890 STANDARD
Accepted in 2012.	Accepted in 2016.
Filters consist of three different groups.	Filters consist of four different groups.
Filter classification is based on 0.4 micron.	Filter classification is based on 1 micron, 2.5 micron and 10 micron sizes
More theoretical.	More realistic.
It is more inefficient in energy consumption in filter selection.	It provides more detailed selection about energy consumption in filter selection.
It is the European standard.	It is the world standard.



EN1822 standard is on part counting methods covering the needs of different applications. Testing according to EN1822 is normally done with an aerosol probe, which can be moved across the entire surface of the filter. This screening measures local efficiencies. The measured local efficiencies are used to calculate the efficiency of the entire filter or leakage of the special area of the filter. The tests are usually applied for new filters in a specific volumetric air flow. U15 and higher efficiency filters should be scanned with the part counting probe designed for this purpose.

The following measurements are made with EN1822;

- Pressure drop in nominal air flow
- Local aggregation efficiencies in MPPS (MPPS: Most Penetrating Particle Size)
- The most effective particle size aggregation efficiency

Filters are classified as follows according to their efficiency at a particle size of 0.3µm according to the EN1822 standard;

- EPA (E10, E11, E12) : Efficient Particulate Air Filter
- HEPA (H13, H14) : High Efficiency Particulate Arresting
- ULPA (U15, U16, U17) : Ultra Low Penetration Air Filte

Filter Group	Filter Class	Integral Values		Local Values	
		Efficiency (%)	Penetration (%)	Efficiency (%)	Penetration (%)
EPA	E10	≥ 85	≤ 15	-	-
	E11	≥ 95	≤ 5	-	-
HEPA	E12	≥ 99,5	≤ 0,5	-	-
	H13	≥ 99,95	≤ 0,05	≥ 99,75	≤ 0,25
ULPA	H14	≥ 99,995	≤ 0,005	≥ 99,975	≤ 0,025
	U15	≥ 99,9995	≤ 0,0005	≥ 99,9975	≤ 0,0025
	U16	≥ 99,99995	≤ 0,00005	≥ 99,99975	≤ 0,00025
	U17	≥ 99,999995	≤ 0,000005	≥ 99,999975	≤ 0,0001



Points to be considered in order to choose the right filter for air cleaning applications;

- Sufficient filter sizes should be used according to the flow rate of the air to be filtered.
- The filter type must be suitable for the operating conditions.
- The type and amount of dust in the incoming air should be considered.
- The limit of permissible dust and other substances in the cleaned air should be kept in front.
- Attention should be paid to the initial pressure drop and final pressure drop values and operating conditions of the filter to be selected.
- The most economical choice should be made for the application to be used.
- Attention should be paid to energy consumption.
- Particular attention should be paid to ensure that there are no leaks from the filter joints in hepa and ulpa filters.
- When deciding on the filter class, properties such as particle size and efficiency should be considered.
- In filters close to the outside air inlets, surface protection should be used.
- Care should be taken that the filters to be used comply with the quality standards.
- Attention should be paid to the filter life of the selected filter, and filters that expire should be replaced on time.

Cost - Time Graph

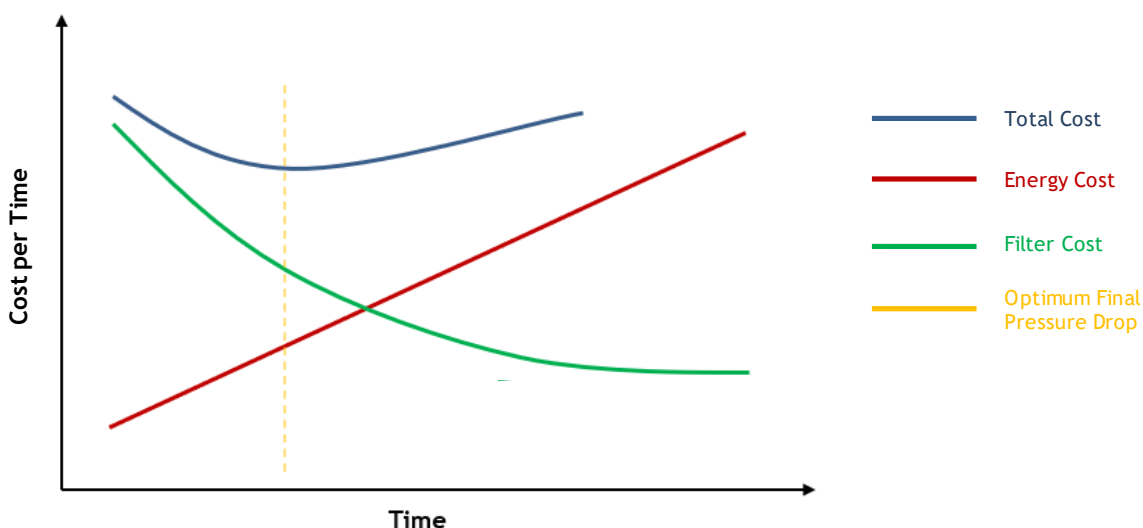



MERV rating is a standard for defining air filter efficiency. It means ‘Minimum Efficiency Reporting Value’. The MERV rating is indicated by numbers from 1 to 16. Filter efficiency increases as it approaches 1 to 16.

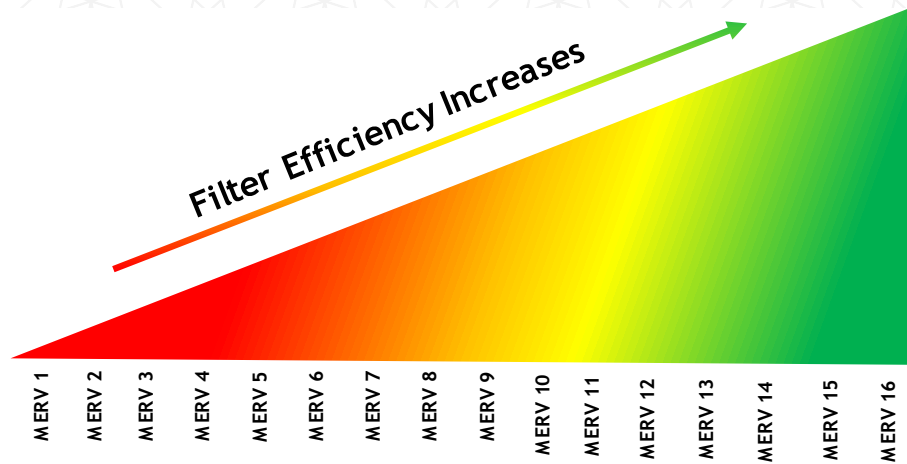

The MERV rating is done in three different size ranges. These are

- 3,0 µm 10,0 µm
 1,0 µm 3,0 µm
 0,3 µm 1,0 µm

MERV Value	0,3 - 1,0 µm	1,0 - 3,0 µm	3,0 - 10,0 µm	Types of things these filters will trap
MERV 1	-	-	Less than %20	Dusts, pollens, carpet fibers
MERV 2	-	-	Less than %20	
MERV 3	-	-	Less than %20	
MERV 4	-	-	Less than %20	
MERV 5	-	-	%34-%20	Spores, cement dusts
MERV 6	-	-	%49-%35	
MERV 7	-	-	%69-%50	
MERV 8	-	-	%85-%70	
MERV 9	-	Less than %50	%85 or better	Lead dust, exhaust gases
MERV 10	-	%64-%50	%85 or better	
MERV 11	-	%79-%65	%85 or better	
MERV 12	-	%89-%80	%85 or better	
MERV 13	Less than %75	%90 or better	%90 or better	Bacteria, tobacco smoke
MERV 14	%84-%75	%90 or better	%90 or better	
MERV 15	%94-%85	%90 or better	%90 or better	
MERV 16	%95 or better	%90 or better	%90 or better	

Efficiency table by MERV rating

Class selection according to ISO 16890



Eurovent Recommendation, published for the selection of filter class, offers a suitable method according to outside air and supply air. To maintain consistency on an international level, the method refers to limit values recommended by WHO. In this recommendation, three categories of outdoor air (ODA) and five categories of supply air (SUP) are defined.

Category	Description	Annual Mean
ODA 1	Low concentration of particulate matter , dusty	PM10 ≥ 2.5 µg/m ³ PM20 ≥ 10 µg/m ³
ODA 2	High concentration of particulate matter	PM15 ≥ 2.5 µg/m ³ PM30 ≥ 10 µg/m ³
ODA 3	Very high concentration of particulate matter	PM15 < 2.5 µg/m ³ PM30 < 10 µg/m ³

Supply Air Classification



According to the hygiene requirement in the environment to be filtrated, the interior spaces are divided into five different classes. This classification is made according to the amount and size of particles per unit volume. This classification should also be considered when choosing filters.

SUP classification according to indoor hygiene requirement is as follows.

Category	Description	Annual Mean	Annual Mean
SUP 1	High hygienic requirements	PM2.5 ≤ 2.5 µg/m ³ PM10 ≤ 5 µg/m ³	Clean rooms ,hospitals , pharmaceutical companies
SUP 2	Medium hygienic requirements	PM2.5 ≤ 5 µg/m ³ PM10 ≤ 10 µg/m ³	Theatres, cinemas , schools , concert halls
SUP 3	Standart hygienic requirements	PM2.5 ≤ 7.5 µg/m ³ PM10 ≤ 15 µg/m ³	Shopping centres , warehouses , copy rooms
SUP 4	Low hygienic requirements	PM2.5 ≤ 10 µg/m ³ PM10 ≤ 20 µg/m ³	Datacentres, underground w parking garages
SUP 5	Very Low hygienic requirements	PM2.5 ≤ 15 µg/m ³ PM10 ≤ 30 µg/m ³	Toilets, storage, rooms , rest rooms

products

coarse pre filters



AFT FILTER®

COARSE

PRE

FILTERS

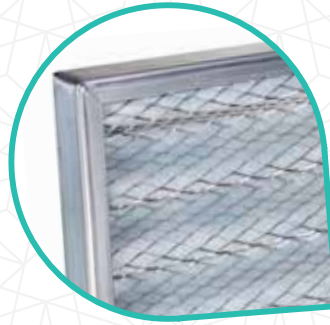

take a breathe



FILTER ROLL & PADS



- G3 / G4 SYNTHETIC PET MEDIA ROLLS
- PAINT STOP /GLASS FIBRE ROLLS
- ACTIVATED CARBON IMPEGRATED POLYESTER FILTER MEDIA ROLLS
- M5 CEILING FILTER MEDIA ROLLS
- POLYURETHANE SPONGE FILTER PADS

PANEL FILTERS



- Z TYPE
 - Z TYPE PET
 - Z TYPE CARDBOARD
 - Z TYPE POL
- FLAT TYPE
 - FLAT TYPE
- METAL (KITCHEN HOOD)

BAG FILTERS



- G3 BAG FILTERS
- G4 BAG FILTERS



FILTER ROLL & PADS



G3 / G4 SYNTHETIC PET
MEDIA ROLLS



PAINT STOP /GLASS
FIBRE ROLLS

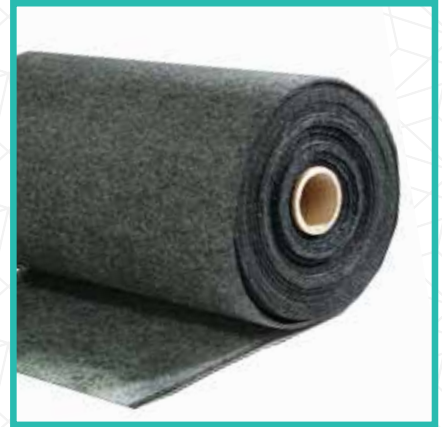

ACTIVATED CARBON IMPEGRATED
POLYESTER FILTER MEDIA ROLLS



M5 CEILING FILTER
MEDIA ROLLS



POLYURETHANE SPONGE
FILTER PADS

APPLICATIONS & ADVANTAGES

- ✓ Used as prefilter for ventilation and air conditioning systems.
- ✓ Used as paint spray and varnishing applications.
- ✓ Used as pre filter in industrial systems and fancoils.
- ✓ High dust holding capacity and low pressure drop.
- ✓ Available as standard rolls or cut as required sizes.

PRODUCT CODE EXPLANATION



Media Class
 3 : G3 acc. To EN779
 4 : G4 acc. To EN779
 PS: Paint Stop Media
 C5: M5 Ceiling Filter
 AC: Activated Carbon
 Impregnated
 PET: POLYESTER
 POL: POLYURETHANE

G3 - G4 SYNTHETIC PET MEDIA ROLLS

**TECHNICAL SPECIFICATIONS**

Filtration Material	:Polyester(PET)
Classification (EN779:2012)	:G3-G4
Classification (ISO16890)	:ePMcoarse
Flammability (DIN53438)	:F1
Final Pressure Drop	:250 Pa
Max. Temperature	:80 °C
Max. Moisture	:100%
Roll Dimensions	:2mx20m



PRODUCT CODE	CLASS EN779	CLASS ISO16890	WIDTH (m)	LENGTH (m)	FILTRATION AREA (m ²)	NOMINAL AIR FLOW (m ³ /h m ²)	INITIAL PRESSURE DROP (± 10 % Pa)	UNIT WEIGHT (g/m ² 10 %)
MR - 3 - PET - 2 - 20	G3	ePMcoarse 45%	2	20	40	5400	35	180
MR - 4 - PET - 2 - 20	G4	ePMcoarse 65%	2	20	40	5400	30	220

PAINT STOP /GLASS FIBRE ROLLS

**TECHNICAL SPECIFICATIONS**

Filtration Material:	Paint StopGlassFibreRolls
Classification (EN779:2012):	G3-G4
Classification (ISO16890):	ePMcoarse
Flammability (DIN53438):	F1
Final Pressure Drop:	250 Pa
Max. Temperature:	120 °C
Max. Moisture:	100%
Roll Dimensions:	2mx20m



PRODUCT CODE	CLASS EN779	CLASS ISO16890	WIDTH (m)	LENGTH (m)	THICK NESS (mm)	FILTRATION AREA (m ²)	NOMINAL AIR FLOW (m ³ /h.)	INITIAL PRESSURE DROP (± 10 % Pa)	INITIAL PRESSURE DROP (± 10 % Pa)
MR- PS - 50 - 2 - 20	G3	ePMcoarse 2 %45	2	20	50	40	5400	25	200
MR - PS - 100 - 2 - 20	G4	ePMcoarse %65	2	20	100	40	5400	40	350

M5 CEILING FILTER MEDIA ROLLS

**TECHNICAL SPECIFICATIONS**

Filtration Material	: Synthetic Fibre
Weight	: 600 g/m ²
Classification (EN779:2012)	: M5
Flammability (DIN53438)	: F1
Final Pressure Drop	: 250 Pa
Max. Temperature	: 90 °C
Max. Moisture	: 100%
Thickness	: 22mm



PRODUCT CODE	CLASS EN779	CLASS ISO16890	WIDTH (m)	LENGTH (m)	FILTRATION AREA (m ²)	NOMINAL AIR FLOW (m ³ /h m ²)	INITIAL PRESSURE DROP (± 10 % Pa)
MR C5 2 20	M5	ePM55% 10	2	20	40	100	40

ACTIVATED CARBON IMPEGRATED POLYESTER FILTER MEDIA ROLLS

**TECHNICAL SPECIFICATIONS**

Filtration Material	: Activated Carbon : Imregnated Polyester
Classification (EN779:2012)	: G3
Classification (ISO16890)	: ePMcoarse
Flammability (DIN53438)	: F1
Final Pressure Drop	: 250 Pa
Max. Temperature	: 90 °C
Max. Moisture	: 100%
Thickness	: 12 mm
Roll Dimensions:	: 2mx20m



PRODUCT CODE	CLASS EN779	CLASS ISO16890	WIDTH (m)	LENGTH (m)	FILTRATION AREA (m ²)	NOMINAL AIR FLOW (m ³ /h m ²)	INITIAL PRESSURE DROP (± 10 % Pa)
MR AC 2 20	G3	ePMcoarse 45%	2	20	40	5400	40

POLYURETHANE SPONGE FILTER PADS

**TECHNICAL SPECIFICATIONS**

Filtration Material	: PolyurethaneSponge
Classification (EN779:2012)	: G2-G3
Flammability (DIN53438)	: F1
Final Pressure Drop	: 250 Pa
Max. Temperature	: 80 °C
Max. Moisture	: 100%
Dimension (cm)	: 150x200 / cut to size



PRODUCT CODE	CLASS EN779	CLASS ISO16890	THICKNESS (mm)	Density (PPI)	NOMINAL AIR FLOW (m ³ /h m ²)	INITIAL PRESSURE DROP (± 10 % Pa)	UNIT WEIGHT (g/m ² 10 %)
MR POL 3 150 200	G3	ePMcoarse 45%	10	20	5400	15	250

PANEL FILTERS



Z TYPE PET FILTER



Z TYPE CARDBOARD FRAME



Z TYPE POL FILTER



METAL (KITCHEN HOOD)
FILTER



FLAT TYPE (FCU) FILTER

APPLICATIONS & ADVANTAGES

- ✓ Industrial ventilation and air conditioning plants
- ✓ Prefiltration of coarse and thinner particulates
- ✓ Prefiltration and separation of particles wherever minimum obstructions are required
- ✓ Ventilation and conditioning in the pharmaceutical and photographic industry and spray paint booths
- ✓ Air treatment plants and filter walls
- ✓ Air filtration in corrosive environments
- ✓ Absorbs grease holds sprays and separates oil vapours

PRODUCT CODE EXPLANATION

CP-4Z-PET-592-592-48

PET: Polyester
GF: Glass Fibre
MET: Metal Mesh
POL: Polyurethane Sponge

Dimensions
W x H x D (mm)

Product CLASS & TYPE
Type 2: G2 acc. To EN 779
COARSE 3: G3 acc. To EN 779
PANEL 4: G4 acc. To EN 779
FILTER

Z: Z type pleated
F: Flat Sheet Media

Z TYPE PET

**TECHNICAL SPECIFICATIONS**

Filter Media	: Polyester(PET)
Frame Material	: Galvanized Sheet Metal
Gasket	: Optional (Polyurethane / EPDM)
Grid	: Metal Mesh
Classification (EN779:2012)	: G3-G4
Classification (ISO 16890)	: ePMcoarse
Final Pressure Drop	: 250 Pa
Max. Temperature	: 80°C
Max. Moisture	: 90%
Rated Face Velocity	: 2,70 m/s



PRODUCT CODE	CLASS EN779	CLASS ISO16890	WIDTH (mm)	HEIGHT (mm)	DEPTH (mm)	FILTRATION AREA	NOMINAL AIR FLOW (m3/h)	INITIAL PRESSURE DROP (± 10 % Pa)
CP-3-Z-PET-287-287-48	G3	ePMcoarse 45 %	287	287	48	0,15	850	45
CP-3-Z-PET-287-592-48	G3	ePMcoarse 45 %	287	592	48	0,30	1700	45
CP-3-Z-PET-490-592-48	G3	ePMcoarse 45 %	490	592	48	0,50	2800	45
CP-3-Z-PET-592-592-48	G3	ePMcoarse 45 %	592	592	48	0,60	3400	45
CP-3-Z-PET-287-287-96	G3	ePMcoarse 45 %	287	287	96	0,25	850	55
CP-3-Z-PET-287-592-96	G3	ePMcoarse 45 %	287	592	96	0,50	1700	55
CP-3-Z-PET-490-592-96	G3	ePMcoarse 45 %	490	592	96	0,85	2800	55
CP-3-Z-PET-592-592-96	G3	ePMcoarse 45 %	592	592	96	1,00	3400	55
CP-4-Z-PET-287-287-48	G4	ePMcoarse 65 %	287	287	48	0,15	850	70
CP-4-Z-PET-287-592-48	G4	ePMcoarse 65 %	287	592	48	0,30	1700	70
CP-4-Z-PET-490-592-48	G4	ePMcoarse 65 %	490	592	48	0,50	2800	70
CP-4-Z-PET-592-592-48	G4	ePMcoarse 65 %	592	592	48	0,60	3400	70
CP-4-Z-PET-287-287-96	G4	ePMcoarse 65 %	287	287	96	0,25	850	45
CP-4-Z-PET-287-592-96	G4	ePMcoarse 65 %	287	592	96	0,50	1700	45
CP-4-Z-PET-490-592-96	G4	ePMcoarse 65 %	490	592	96	0,85	2800	45
CP-4-Z-PET-592-592-96	G4	ePMcoarse 65 %	592	592	96	1,00	3400	45

* Irregular sizes are available.

* Technical values are based on standard 125g/m² G3 fibre & 200 g/m² G4 fibre.



Air Flow (% of nominal airflow)

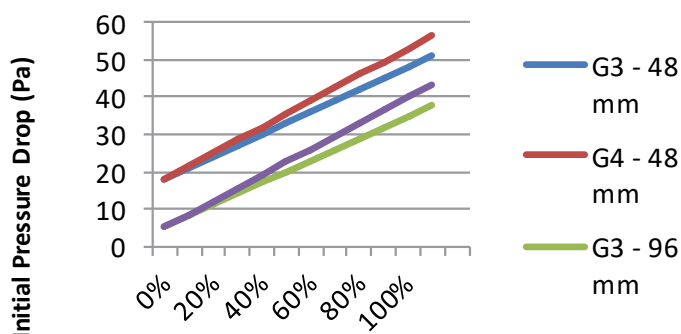

Z TYPE POL



TECHNICAL SPECIFICATIONS

Filter Media	: Polyurethane (POL)
Frame Material:	: Galvanized Sheet Metal
Gasket	: Optional (Polyurethane / EPDM)
Grid	: Metal Mesh
Classification (EN779:2012)	: G3-G4
Classification (ISO 16890)	: ePMcoarse
Final Pressure Drop	: 250 Pa
Max. Temperature	: 80°C
Max. Moisture	: 90%
Rated Face Velocity	: 2,70 m/s



PRODUCT CODE	CLASS EN779	CLASS ISO16890	WIDTH (mm)	HEIGHT (mm)	DEPTH (mm)	FILTRATION AREA	NOMINAL AIR FLOW (m3/h)	INITIAL PRESSURE DROP (± 10 % Pa)
CP-3-Z-POL-287-287-48	G3	ePMcoarse 45 %	287	287	48	0,15	850	55
CP-3-Z-POL-287-592-48	G3	ePMcoarse 45 %	287	592	48	0,30	1700	55
CP-3-Z-POL-490-592-48	G3	ePMcoarse 45 %	490	592	48	0,50	2800	55
CP-3-Z-POL-592-592-48	G3	ePMcoarse 45 %	592	592	48	0,60	3400	55
CP-3-Z-POL-287-287-96	G3	ePMcoarse 45 %	287	287	96	0,25	850	40
CP-3-Z-POL-287-592-96	G3	ePMcoarse 45 %	287	592	96	0,50	1700	40
CP-3-Z-POL-490-592-96	G3	ePMcoarse 45 %	490	592	96	0,85	2800	40
CP-3-Z-POL-592-592-96	G3	ePMcoarse 45 %	592	592	96	1,00	3400	40
CP-4-Z-POL-287-287-48	G4	ePMcoarse 65 %	287	287	48	0,15	850	70
CP-4-Z-POL-287-592-48	G4	ePMcoarse 65 %	287	592	48	0,30	1700	70
CP-4-Z-POL-490-592-48	G4	ePMcoarse 65 %	490	592	48	0,50	2800	70
CP-4-Z-POL-592-592-48	G4	ePMcoarse 65 %	592	592	48	0,60	3400	70
CP-4-Z-POL-287-287-96	G4	ePMcoarse 65 %	287	287	96	0,25	850	55
CP-4-Z-POL-287-592-96	G4	ePMcoarse 65 %	287	592	96	0,50	1700	55
CP-4-Z-POL-490-592-96	G4	ePMcoarse 65 %	490	592	96	0,85	2800	55
CP-4-Z-POL-592-592-96	G4	ePMcoarse 65 %	592	592	96	1,00	3400	55

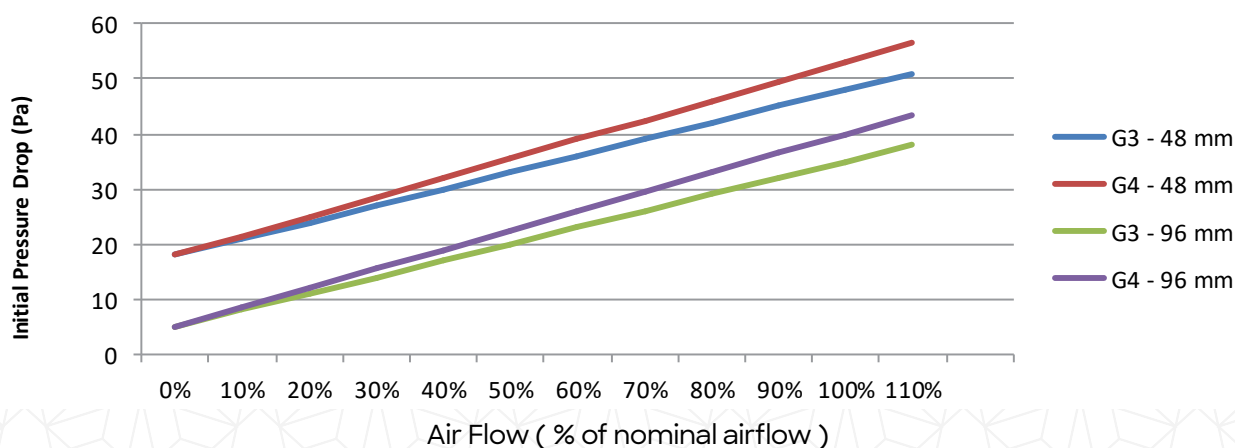

Z TYPE CARDBOARD

**TECHNICAL SPECIFICATIONS**

Filter Media	: One side mesh laminated PET
Frame Material	: Cardboard
Gasket	: Optional (Polyurethane / EPDM)
Classification (EN779:2012)	: G3-G4
Classification (ISO 16890)	: ePMcoarse
Final Pressure Drop	: 250 Pa
Max. Temperature	: 80 °C
Max. Moisture	: 90%
Rated Face Velocity	: 2,70 m/s



PRODUCT CODE	CLASS EN779	CLASS ISO16890	WIDTH (mm)	HEIGHT (mm)	DEPTH (mm)	FILTRATION AREA	NOMINAL AIR FLOW (m ³ /h)	INITIAL PRESSURE DROP (± 10 % Pa)
CCP-3-Z-PET-287-287-48	G3	ePMcoarse 45 %	287	287	48	0,15	850	45
CCP-3-Z-PET-287-592-48	G3	ePMcoarse 45 %	287	592	48	0,30	1700	45
CCP-3-Z-PET-490-592-48	G3	ePMcoarse 45 %	490	592	48	0,50	2800	45
CCP-3-Z-PET-592-592-48	G3	ePMcoarse 45 %	592	592	48	0,60	3400	45
CCP-4-Z-PET-287-287-48	G4	ePMcoarse 65 %	287	287	48	0,15	850	60
CCP-4-Z-PET-287-592-48	G4	ePMcoarse 65 %	287	592	48	0,30	1700	60
CCP-4-Z-PET-490-592-48	G4	ePMcoarse 65 %	490	592	48	0,50	2800	60
CCP-4-Z-PET-592-592-48	G4	ePMcoarse 65 %	592	592	48	0,60	3400	60

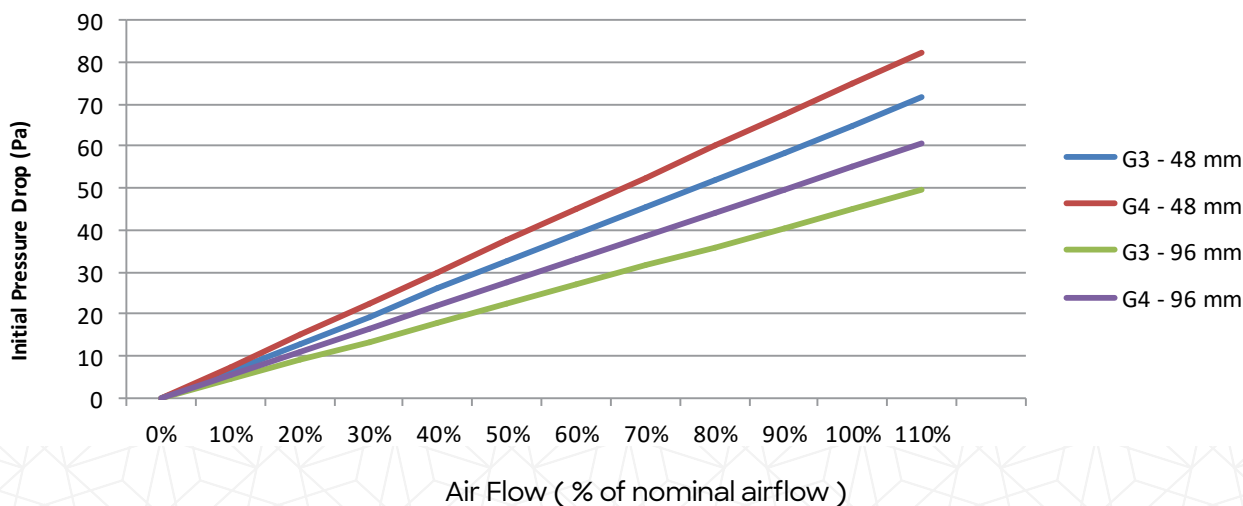

FLAT TYPE



TECHNICAL SPECIFICATIONS

Filter Media	: Polyester(Pet) / Polyurethane (Pol)
Frame Material	: Galvanized Steel
Gasket	: Optional (Polyurethane / EPDM)
Grid	: Two sides metal mesh
Classification (EN779:2012)	: G3-G4
Classification (ISO 16890)	: ePMcoarse
Final Pressure Drop	: 250 Pa
Max. Temperature	: 75 °C
Max. Moisture	: 90%
Rated Face Velocity	: 2,70 m/s



PRODUCT CODE	CLASS EN779	CLASS ISO16890	WIDTH (mm)	HEIGHT (mm)	DEPTH (mm)	FILTRATION AREA	NOMINAL AIR FLOW (m3/h)	INITIAL PRESSURE DROP (± 10 % Pa)
CP-4-F-POL-200-600-10	G3	ePMcoarse 45 %	200	600	10	0,12	1150	35
CP-4-F-POL200-800-10	G3	ePMcoarse 45 %	200	800	10	0,16	1450	35
CP-4-F-POL-200-1000-10	G3	ePMcoarse 45 %	200	1000	10	0,20	1950	35
CP-4-F-POL-200-120010	G3	ePMcoarse 45 %	200	1200	10	0,24	2350	35
CP-4-F-PET-200-600-10	G4	ePMcoarse 65 %	200	600	25	0,12	1150	45
CP-4-F-PET-200-800-10	G4	ePMcoarse 65 %	200	800	25	0,16	1450	45
CP-4-F-PET-200-1000-10	G4	ePMcoarse 65 %	200	1000	25	0,20	1950	45
CP-4F-PET-200-1200-10	G4	ePMcoarse 65 %	200	1200	25	0,24	2350	45

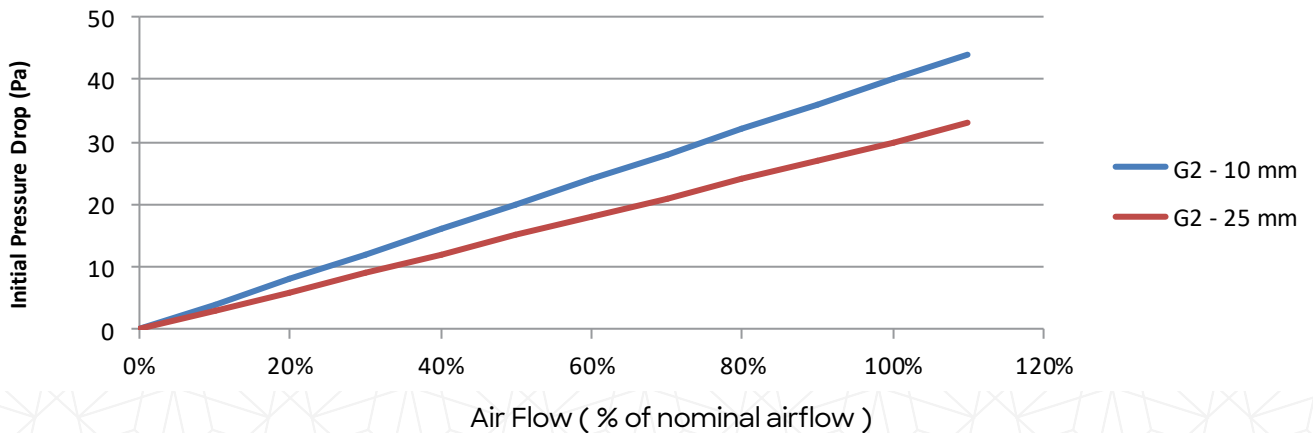

METAL KITCHEN HOOD FILTER

TECHNICAL SPECIFICATIONS

Filter Media	: Expanded Metal Mesh
Frame Material	: Galvanized
Gasket	: Optional (Polyurethane / EPDM)
Classification (EN779:2012)	: G2
Classification (ISO 16890)	: ePMcoarse 35%
Final Pressure Drop	: 250 Pa
Max. Temperature	: 100 °C
Max. Moisture	: 100%
Rated Face Velocity	: 2,70 m/s



PRODUCT CODE	CLASS EN779	CLASS ISO16890	WIDTH (mm)	HEIGHT (mm)	DEPTH (mm)	FILTRATION AREA	NOMINAL AIR FLOW (m3/h)	INITIAL PRESSURE DROP (± 10 % Pa)
CP-2-Z-MET-287-592-24	G2	ePMcoarse 35 %	287	592	24	0,42	1700	25
CP-2-Z-MET-490-592-24	G2	ePMcoarse 35 %	287	592	24	0,65	2800	25
CP-2-Z-MET-592-592-24	G2	ePMcoarse 35 %	490	592	24	0,80	3400	25
CP-2-Z-MET-287-592-48	G2	ePMcoarse 35 %	592	592	24	0,60	1700	20
CP-2-Z-MET-490-592-48	G2	ePMcoarse 35 %	287	592	48	0,98	2800	20
CP-2-Z-MET-592-592-48	G2	ePMcoarse 35 %	287	592	48	1,20	3400	20



COARSE BAG FILTERS G3 G4



TECHNICAL SPECIFICATIONS

Filter Media	: Synthetic Polyester
Frame Material	: Galvanized Sheet Metal
Frame Thickness	: 20-25 mm
Classification (EN779:2012)	: G3-G4
Classification (ISO 16890)	: ePMcoarse 45%-65%
Final Pressure Drop	: 250 Pa
Max. Temperature	: 75 °C
Max. Moisture	: 90%
Rated Face Velocity	: 2,70 m/s



PRODUCT CODE	CLASS EN779	CLASS ISO16890	WIDTH (mm)	HEIGHT (mm)	DEPTH (mm)	NUMBER OF POCKETS	FILTRATION AREA (m2)	NOMINAL AIR FLOW (m3/h)	INITIAL PRESSURE DROP (± 10 % Pa)
BF-3-25-287-592-360-3	G3	ePMcoarse 45 %	287	592	360	3	1,30	1700	45
BF-3-25-490-592-360-5	G3	ePMcoarse 45 %	490	592	360	5	2,20	2800	45
BF-3-25-592-592-360-6	G3	ePMcoarse 45 %	592	592	360	6	2,60	3400	45
BF-3-25-287-592-600-3	G3	ePMcoarse 45 %	287	592	600	3	2,20	1700	35
BF-3-25-490-592-600-5	G3	ePMcoarse 45 %	490	592	600	5	3,70	2800	35
BF-3-25-592-592-600-6	G3	ePMcoarse 45 %	592	592	600	6	4,40	3400	35
BF-4-25-287-592-360-3	G4	ePMcoarse 65 %	287	592	360	3	1,30	1700	60
BF-4-25-490-592-360-5	G4	ePMcoarse 65 %	490	592	360	5	2,20	2800	60
BF-4-25-592-592-360-6	G4	ePMcoarse 65 %	592	592	360	6	2,60	3400	60
BF-4-25-287-592-600-3	G4	ePMcoarse 65 %	287	592	600	3	2,20	1700	55
BF-4-25-490-592-600-5	G4	ePMcoarse 65 %	490	592	600	5	3,70	2800	55
BF-4-25-592-592-600-6	G4	ePMcoarse 65 %	592	592	600	6	4,40	3400	55

APPLICATIONS & ADVANTAGES

- ✓ Pre filtration in high air flow systems
- ✓ Final filtration of suspended particles.
- ✓ Atmosphere control in hospitals ,laboratories , clean rooms,processing data centres
- ✓ Comfort air conditioning applications

PRODUCT CODE EXPLANATION

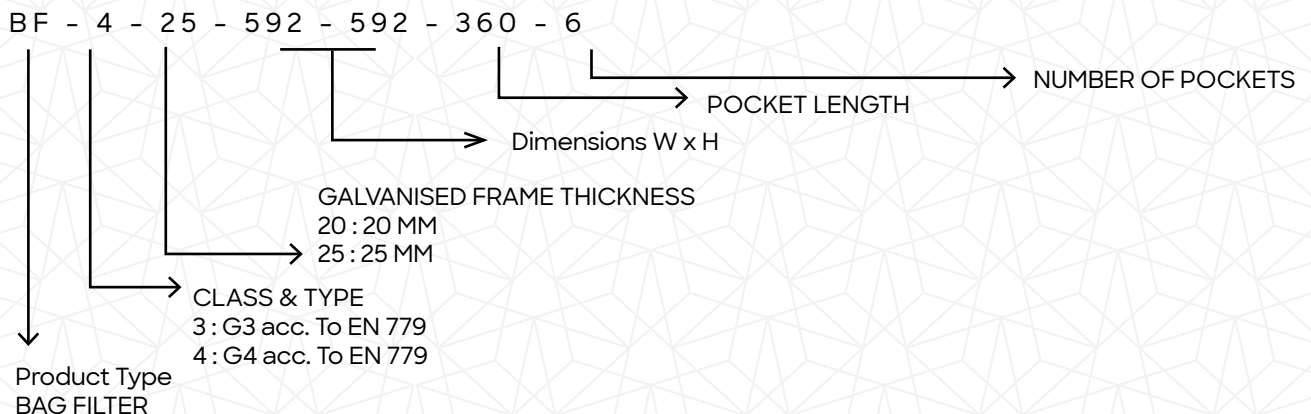

products

medium & fine filters



MEDIUM

& FINE

FILTERS



BAG FILTERS



- M5-M6 BAG FILTERS
- F7-F8 BAG FILTERS

PANEL FILTERS



- PLASTIC FRAME
- GALVANIZED FRAME
- HEADER TYPE PANEL FILTERS

V COMPACT FILTERS



- STD SERIES
- PRO SERIES

V BANK FILTERS



BAG FILTERS



M5 BAG FILTER



M6 BAG FILTER



F8 BAG FILTER



F7 BAG FILTER

PRODUCT CODE EXPLANATION

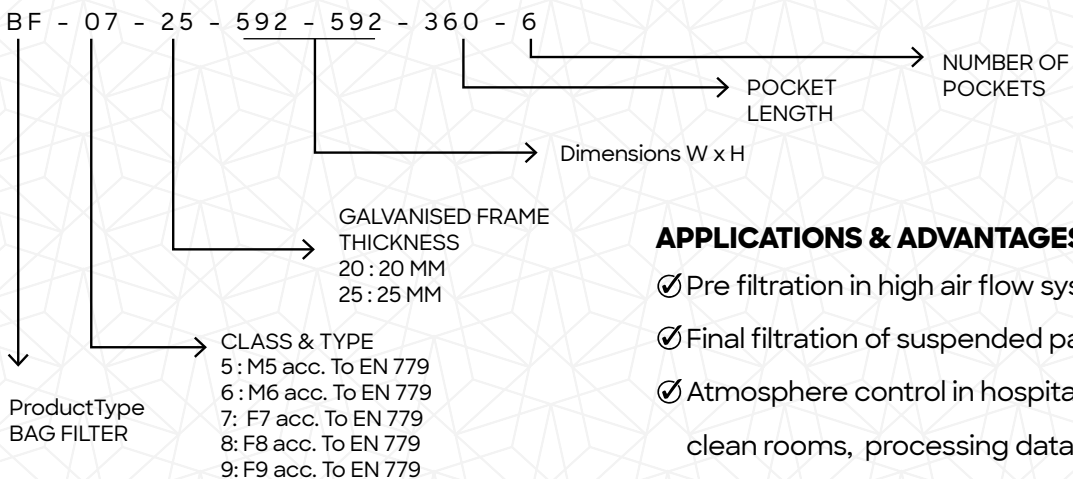

APPLICATIONS & ADVANTAGES

- ✓ Pre filtration in high air flow systems
- ✓ Final filtration of suspended particles.
- ✓ Atmosphere control in hospitals ,laboratories , clean rooms, processing data centres
- ✓ Comfort air conditioning applications



TECHNICAL SPECIFICATIONS

Filter Media : Synthetic Polyester
 Frame Material : Galvanized Sheet Metal
 Frame Thickness : 20-25 mm
 Classification (EN779:2012) : M5-M6
 Classification (ISO 16890) : ePM10
 Final Pressure Drop : 450 Pa
 Max. Temperature : 80 °C
 Max. Moisture : 90%
 Rated Face Velocity : 2,70 m/s



PRODUCT CODE	CLASS EN779	CLASS ISO16890	WIDTH (mm)	HEIGHT (mm)	DEPTH (mm)	NUMBER OF POCKETS	FILTRATION AREA (m2)	NOMINAL AIR FLOW (m3/h)	INITIAL PRESSURE DROP (± 10 % Pa)
BF-5-25-287-592-360-3	M5	ePM10 55%	287	592	360	3	1,30	1700	90
BF-5-25-490-592-360-5	M5	ePM10 55%	490	592	360	5	2,10	2800	90
BF-5-25-592-592-360-6	M5	ePM10 55%	592	592	360	6	2,60	3400	90
BF-5-25-287-592-360-4	M5	ePM10 55%	287	592	360	4	1,70	1700	90
BF-5-25-490-592-360-6	M5	ePM10 55%	490	592	360	6	2,50	2800	90
BF-5-25-592-592-360-8	M5	ePM10 55%	592	592	360	8	3,40	3400	70
BF-5-25-287-592-535-3	M5	ePM10 55%	287	592	535	3	1,90	1700	70
BF-5-25-490-592-535-5	M5	ePM10 55%	490	592	535	5	3,20	2800	70
BF-5-25-592-592-535-6	M5	ePM10 55%	592	592	535	6	3,80	3400	70
BF-5-25-287-592-535-4	M5	ePM10 55%	287	592	535	4	2,50	1700	70
BF-5-25-490-592-535-6	M5	ePM10 55%	490	592	535	6	3,80	2800	65
BF-5-25-592-592-535-8	M5	ePM10 55%	592	592	535	8	5,00	3400	65
BF-5-25-287-592-635-3	M5	ePM10 55%	287	592	635	3	2,30	1700	65
BF-5-25-490-592-635-5	M5	ePM10 55%	490	592	635	5	3,80	2800	65
BF-5-25-592-592-635-6	M5	ePM10 55%	592	592	635	6	4,60	3400	65
BF-5-25-287-592-635-4	M5	ePM10 55%	287	592	635	4	3,00	1700	100
BF-5-25-490-592-635-6	M5	ePM10 70%	490	592	635	6	4,50	2800	100
BF-5-25-592-592-635-8	M5	ePM10 70%	592	592	635	8	6,00	3400	100
BF-6-25-287-592-360-3	M6	ePM10 70%	287	592	360	3	1,30	1700	100
BF-6-25-490-592-360-5	M6	ePM10 70%	490	592	360	5	2,10	2800	100
BF-6-25-592-592-360-6	M6	ePM10 70%	592	592	360	6	2,60	3400	100
BF-6-25-287-592-360-4	M6	ePM10 70%	287	592	360	4	1,70	1700	100
BF-6-25-490-592-360-6	M6	ePM10 70%	490	592	360	6	2,50	2800	100
BF-6-25-592-592-360-8	M6	ePM10 70%	592	592	360	8	3,40	3400	100
BF-6-25-287-592-535-3	M6	ePM10 70%	287	592	535	3	1,90	1700	100
BF-6-25-490-592-535-5	M6	ePM10 70%	490	592	535	5	3,20	2800	100
BF-6-25-592-592-535-6	M6	ePM10 70%	592	592	535	6	3,80	3400	80
BF-6-25-287-592-535-4	M6	ePM10 70%	287	592	535	4	2,50	1700	80
BF-6-25-490-592-535-6	M6	ePM10 70%	490	592	535	6	3,80	2800	80
BF-6-25-592-592-535-8	M6	ePM10 70%	592	592	535	8	5,00	3400	80
BF-6-25-287-592-635-3	M6	ePM10 70%	287	592	635	3	2,30	1700	80
BF-6-25-490-592-635-5	M6	ePM10 70%	490	592	635	5	3,80	2800	75
BF-6-25-592-592-635-6	M6	ePM10 70%	592	592	635	6	4,60	3400	75
BF-6-25-287-592-635-4	M6	ePM10 70%	287	592	635	4	3,00	1700	75
BF-6-25-490-592-635-6	M6	ePM10 70%	490	592	635	6	4,50	2800	75
BF-6-25-592-592-635-8	M6	ePM10 70%	592	592	635	8	6,00	3400	75



TECHNICAL SPECIFICATIONS

Filter Media	: Synthetic Polyester
Frame Material	: Galvanized Sheet Metal
Frame Thickness	: 20-25 mm
Classification (EN779:2012)	: F7 - F8 EN 779
Classification (ISO 16890)	: ePM 2.5 /ePM1
Final Pressure Drop	: 250 Pa
Max. Temperature	: 80 °C
Max. Moisture	: 90%
Rated Face Velocity	: 2,70 m/s



PRODUCT CODE	CLASS EN779	CLASS ISO16890	WIDTH (mm)	HEIGHT (mm)	DEPTH (mm)	NUMBER OF POCKETS	FILTRATION AREA (m2)	NOMINAL AIR FLOW (m3/h)	INITIAL PRESSURE DROP (± 10 % Pa)
BF-7-25-287-592-360-3	F7	ePM2.5 65%	287	592	360	3	1,30	1700	95
BF-7-25-490-592-360-5	F7	ePM2.5 65%	490	592	360	5	2,10	2800	95
BF-7-25-592-592-360-6	F7	ePM2.5 65%	592	592	360	6	2,60	3400	95
BF-7-25-287-592-360-4	F7	ePM2.5 65%	287	592	360	4	1,70	1700	95
BF-7-25-490-592-360-6	F7	ePM2.5 65%	490	592	360	6	2,50	2800	95
BF-7-25-592-592-360-8	F7	ePM2.5 65%	592	592	360	8	3,40	3400	95
BF-7-25-287-592-535-3	F7	ePM2.5 65%	287	592	535	3	1,90	1700	85
BF-7-25-490-592-535-5	F7	ePM2.5 65%	490	592	535	5	3,20	2800	85
BF-7-25-592-592-535-6	F7	ePM2.5 65%	592	592	535	6	3,80	3400	85
BF-7-25-287-592-535-4	F7	ePM2.5 65%	287	592	535	4	2,50	1700	85
BF-7-25-490-592-535-6	F7	ePM2.5 65%	490	592	535	6	3,80	2800	85
BF-7-25-592-592-535-8	F7	ePM2.5 65%	592	592	535	8	5,00	3400	85
BF-7-25-287-592-635-3	F7	ePM2.5 65%	287	592	635	3	2,30	1700	70
BF-7-25-490-592-635-5	F7	ePM2.5 65%	490	592	635	5	3,80	2800	70
BF-7-25-592-592-635-6	F7	ePM2.5 65%	592	592	635	6	4,60	3400	70
BF-7-25-287-592-635-4	F7	ePM2.5 65%	287	592	635	4	3,00	1700	70
BF-7-25-490-592-635-6	F7	ePM2.5 65%	490	592	635	6	4,50	2800	70
BF-7-25-592-592-635-8	F7	ePM2.5 65%	592	592	635	8	6,00	3400	70
BF-8-25-287-592-360-3	F8	ePM1 75%	287	592	360	3	1,30	1700	115
BF-8-25-490-592-360-5	F8	ePM1 75%	490	592	360	5	2,10	2800	115
BF-8-25-592-592-360-6	F8	ePM1 75%	592	592	360	6	2,60	3400	115
BF-8-25-287-592-360-4	F8	ePM1 75%	287	592	360	4	1,70	1700	115
BF-8-25-490-592-360-6	F8	ePM1 75%	490	592	360	6	2,50	2800	115
BF-8-25-592-592-360-8	F8	ePM1 75%	592	592	360	8	3,40	3400	115
BF-8-25-287-592-535-3	F8	ePM1 75%	287	592	535	3	1,90	1700	95
BF-8-25-490-592-535-5	F8	ePM1 75%	490	592	535	5	3,20	2800	95
BF-8-25-592-592-535-6	F8	ePM1 75%	592	592	535	6	3,80	3400	95
BF-8-25-287-592-535-4	F8	ePM1 75%	287	592	535	4	2,50	1700	95
BF-8-25-490-592-535-6	F8	ePM1 75%	490	592	535	6	3,80	2800	95
BF-8-25-592-592-535-8	F8	ePM1 75%	592	592	535	8	5,00	3400	95
BF-8-25-287-592-635-3	F8	ePM1 75%	287	592	635	3	2,30	1700	85
BF-8-25-490-592-635-5	F8	ePM1 75%	490	592	635	5	3,80	2800	85
BF-8-25-592-592-635-6	F8	ePM1 75%	592	592	635	6	4,60	3400	85
BF-8-25-287-592-635-4	F8	ePM1 75%	287	592	635	4	3,00	1700	85
BF-8-25-490-592-635-6	F8	ePM1 75%	490	592	635	6	4,50	2800	85
BF-8-25-592-592-635-8	F8	ePM1 75%	592	592	635	8	6,00	3400	85

MEDIUM & FINE PANEL FILTERS



PLASTIC FRAME PANELS



GALVANIZED FRAME PANELS



HEADER TYPE PANEL

APPLICATIONS & ADVANTAGES

- ✓ Low initial pressure
- ✓ High dust holding capacity
- ✓ PU Gasket application upon request
- ✓ Low energy consumption
- ✓ High filtration area
- ✓ Ventilation and air conditioning plants for the separation of fine particles
- ✓ Pre filtration and main filtration in plants with high flow rate
- ✓ High efficiency filtration incritical applications
- ✓ Air purifications of smokes and pollens

PRODUCT CODE EXPLANATION

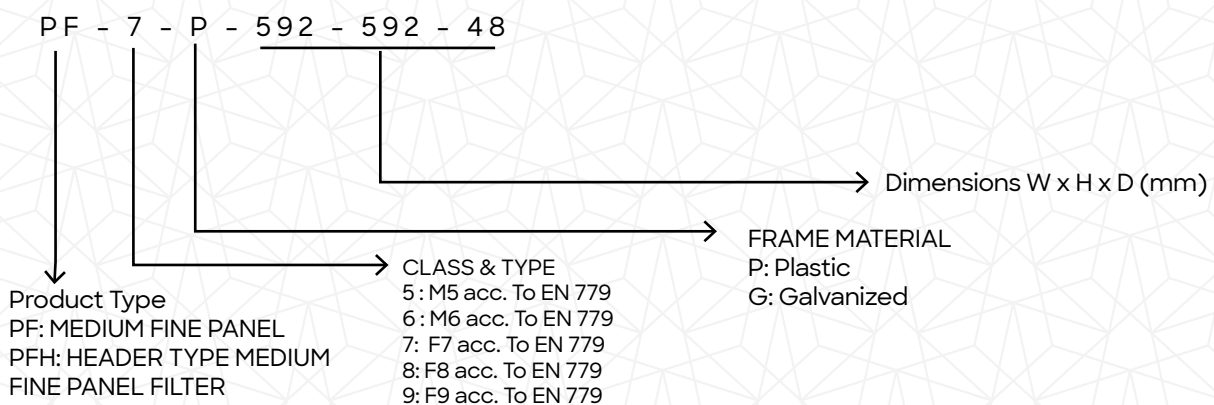

PLASTIC FRAME PANELS

TECHNICAL SPECIFICATIONS

Filter Media	: Minipleat Micro Glass Fibre
Frame Material	: Plastic
Classification (EN779:2012)	: M5-F9
Classification (ISO 16890)	: ePM10-ePM2.5- ePM1
Gasket	: Optional (Polyurethane / EPDM)
Seperator	: Hotmelt
Sealant	: 2K Polyurethane
Final Pressure Drop	: 450 Pa
Max. Temperature	: 80 °C
Max. Moisture	: 90 % rH



PRODUCT CODE	CLASS EN779	CLASS ISO16890	WIDTH (mm)	HEIGHT (mm)	DEPTH (mm)	FILTRATION AREA (m ²)	NOMINAL AIR FLOW (m ³ /h)	INITIAL PRESSURE DROP (± 10 % Pa)
PF-5-P-287-287-48	M5	ePM10 60%	287	287	48	1,50	500	50
PF-5-P-287-592-48	M5	ePM10 60%	287	592	48	3,00	1000	50
PF-5-P-490-592-48	M5	ePM10 60%	490	592	48	5,00	1650	50
PF-5-P-592-592-48	M5	ePM10 60%	592	592	48	6,00	2000	50
PF-5-P-287-287-96	M5	ePM10 60%	287	287	96	3,00	750	60
PF-5-P-287-592-96	M5	ePM10 60%	287	592	96	6,00	1500	60
PF-5-P-490-592-96	M5	ePM10 60%	490	592	96	10,00	2500	60
PF-5-P-592-592-96	M5	ePM10 60%	592	592	96	12,00	3000	60
PF-7-P-287-287-48	F7	ePM1 60%	287	287	48	1,50	500	80
PF-7-P-287-592-48	F7	ePM1 60%	287	592	48	3,00	1000	80
PF-7-P-490-592-48	F7	ePM1 60%	490	592	48	5,00	1650	80
PF-7-P-592-592-48	F7	ePM1 60%	592	592	48	6,00	2000	80
PF-7-P-287-287-96	F7	ePM1 60%	287	287	96	3,00	750	90
PF-7-P-287-592-96	F7	ePM1 60%	287	592	96	6,00	1500	90
PF-7-P-490-592-96	F7	ePM1 60%	490	592	96	10,00	2500	90
PF-7-P-592-592-96	F7	ePM1 60%	592	592	96	12,00	3000	90
PF-9-P-287-287-48	F9	ePM1 85%	287	287	48	1,50	500	140
PF-9-P-287-592-48	F9	ePM1 85%	287	592	48	3,00	1000	140
PF-9-P-490-592-48	F9	ePM1 85%	490	592	48	5,00	1650	140
PF-9-P-592-592-48	F9	ePM1 85%	592	592	48	6,00	2000	140
PF-9-P-287-287-96	F9	ePM1 85%	287	287	96	3,00	750	150
PF-9-P-287-592-96	F9	ePM1 85%	287	592	96	6,00	1500	150
PF-9-P-490-592-96	F9	ePM1 85%	490	592	96	10,00	2500	150
PF-9-P-592-592-96	F9	ePM1 85%	592	592	96	12,00	3000	150

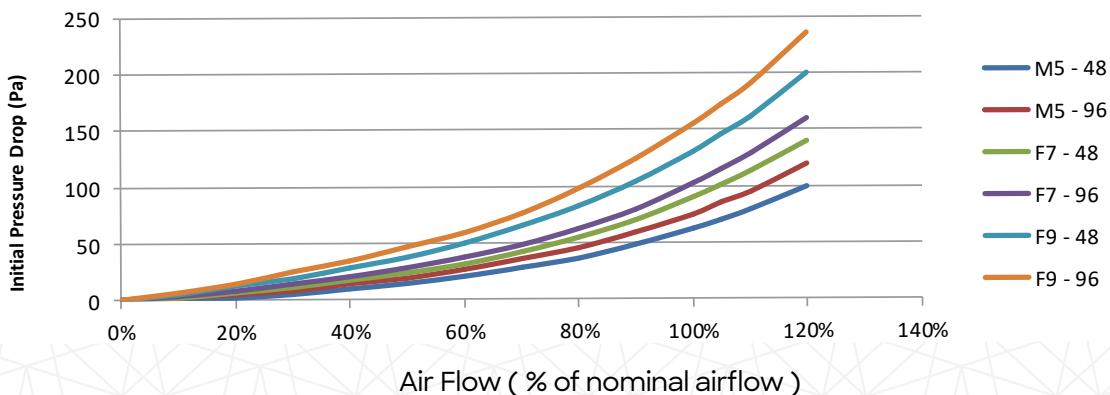

GALVANIZED FRAME PANELS



TECHNICAL SPECIFICATIONS

Filter Media : Minipleat Micro Glass Fibre
 Frame Materia : Galvanized Sheet Metal
 Classification (EN779:2012) : M5 - F9
 Classification (ISO 16890) : ePM10-ePM2.5- ePM1
 Gasket : Optional (Polyurethane / EPDM)
 Seperator : Hotmelt
 Sealant : 2K Polyurethane
 Final Pressure Drop : 450 Pa
 Max. Temperature : 70 °C
 Max. Moisture : 90%



PRODUCT CODE	CLASS EN779	CLASS ISO16890	WIDTH (mm)	HEIGHT (mm)	DEPTH (mm)	NOMINAL AIR FLOW (m3/h)	INITIAL PRESSURE DROP (± 10% Pa)
PF-5-G-287-287-48	M5	ePM10 60%	287	287	48	500	50
PF-5-G-287-592-48	M5	ePM10 60%	287	592	48	1000	50
PF-5-G-490-592-48	M5	ePM10 60%	490	592	48	1650	50
PF-5-G-592-592-48	M5	ePM10 60%	592	592	48	2000	50
PF-5-G-287-287-96	M5	ePM10 60%	287	287	96	750	60
PF-5-G-287-592-96	M5	ePM10 60%	287	592	96	1500	60
PF-5-G-490-592-96	M5	ePM10 60%	490	592	96	2500	60
PF-5-G-592-592-96	M5	ePM10 60%	592	592	96	3000	60
PF-7-G-287-287-48	F7	ePM1 60%	287	287	48	500	80
PF-7-G-287-592-48	F7	ePM1 60%	287	592	48	1000	80
PF-7G-490-592-48	F7	ePM1 60%	490	592	48	1650	80
PF-7-G-592-592-48	F7	ePM1 60%	592	592	48	2000	80
PF-7-G-287-287-96	F7	ePM1 60%	287	287	96	750	90
PF-7-G-287-592-96	F7	ePM1 60%	287	592	96	1500	90
PF-7-G-490-592-96	F7	ePM1 60%	490	592	96	2500	90
PF-7-G-592-592-96	F7	ePM1 60%	592	592	96	3000	90
PF-9-G-287-287-48	F9	ePM1 85%	287	287	48	500	140
PF-9-G-287-592-48	F9	ePM1 85%	287	592	48	1000	140
PF-9-G-490-592-48	F9	ePM1 85%	490	592	48	1650	140
PF-9-G-592-592-48	F9	ePM1 85%	592	592	48	2000	140
PF-9-G-287-287-96	F9	ePM1 85%	287	287	96	750	150
PF-9-G-287-592-96	F9	ePM1 85%	287	592	96	1500	150
PF-9-G-490-592-96	F9	ePM1 85%	490	592	96	2500	150
PF-9-G-592-592-96	F9	ePM1 85%	592	592	96	3000	150

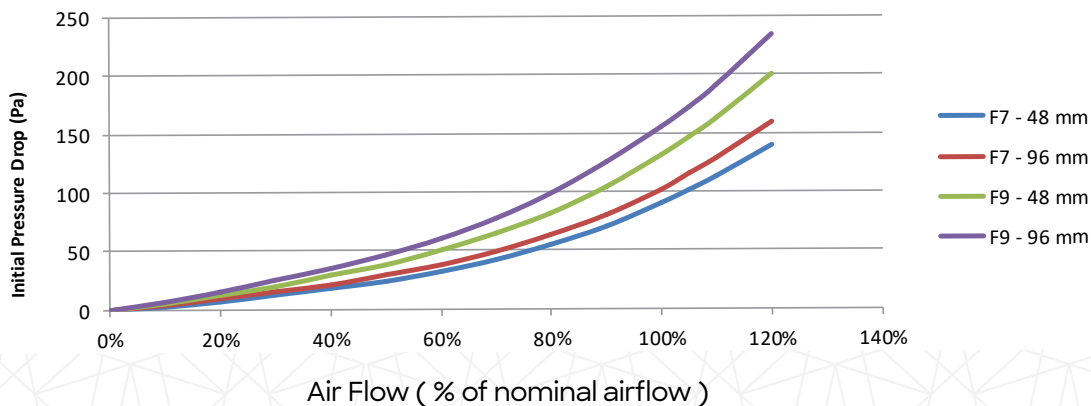

HEADER TYPE PANELS

TECHNICAL SPECIFICATIONS

Filter Media : Minipleat Micro Glass Fibre
 Frame Material : Plastic
 Header Thickness : 25 mm for 100 mm Frame
 22 mm for 150 mm Frame
 Classification (EN779:2012) : M5-F9
 Classification (ISO 16890) : ePM1, Epm2,5, ePM10
 Gasket : Optional (Polyurethane / EPDM)
 Separator: : Hotmelt
 Sealant : 2K Polyurethane
 Final Pressure Drop : 450 Pa
 Max. Temperature : 80 °C
 Max. Moisture : 90%



PRODUCT CODE	CLASS EN779	CLASS ISO16890	WIDTH (mm)	HEIGHT (mm)	DEPTH (mm)	FILTRATION AREA (m ²)	NOMINAL AIR FLOW (m ³ /h)	INITIAL PRESSURE DROP (± 10% Pa)
PFH-6-287-592-100	M6	ePM10 70%	287	592	100	4,50	1700	80
PFH-6-490-592-100	M6	ePM10 70%	490	592	100	7,50	2850	80
PFH-6-592-592-100	M6	ePM10 70%	592	592	100	9,00	3400	80
PFH-7-287-592-100	F7	ePM1 60%	287	592	100	4,50	1700	120
PFH-7-490-592-100	F7	ePM1 60%	490	592	100	7,50	2850	120
PFH-7-592-592-100	F7	ePM1 60%	592	592	100	9,00	3400	120
PFH-8-287-592-100	F8	ePM1 70%	287	592	100	4,50	1700	140
PFH-8-490-592-100	F8	ePM1 70%	490	592	100	7,50	2850	140
PFH-8-592-592-100	F8	ePM1 70%	592	592	100	9,00	3400	140
PFH-9-287-592-100	F9	ePM1 85%	287	592	100	4,50	1700	160
PFH-9-490-592-100	F9	ePM1 85%	490	592	100	7,50	2850	160
PFH-9-592-592-100	F9	ePM1 85%	592	592	100	9,00	3400	160
PFH-6-287-592-150	M6	ePM10 70%	287	592	150	6,25	1700	110
PFH-6-490-592-150	M6	ePM10 70%	490	592	150	10,40	2850	110
PFH-6-592-592-150	M6	ePM10 70%	592	592	150	12,5	3400	110
PFH-7-287-592-150	F7	ePM1 60%	287	592	150	6,25	1700	135
PFH-7-490-592-150	F7	ePM1 60%	490	592	150	10,40	2850	135
PFH-7-592-592-150	F7	ePM1 60%	592	592	150	12,5	3400	135
PFH-8-287-592-150	F8	ePM1 70%	287	592	150	6,25	1700	160
PFH-8-490-592-150	F8	ePM1 70%	490	592	150	10,40	2850	160
PFH-8-592-592-150	F8	ePM1 70%	592	592	150	12,5	3400	160
PFH-9-287-592-150	F9	ePM1 85%	287	592	150	6,25	1700	180
PFH-9-490-592-150	F9	ePM1 85%	490	592	150	10,40	2850	180
PFH-9-592-592-150	F9	ePM1 85%	592	592	150	12,5	3400	180

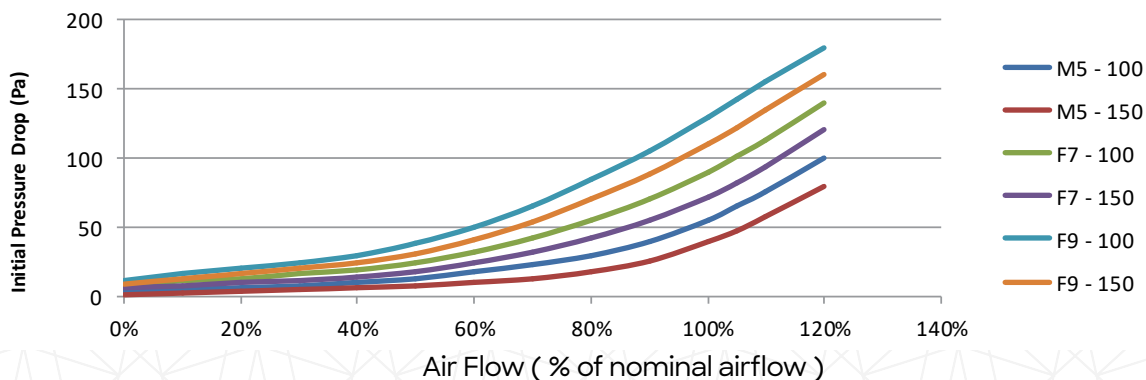

MEDIUM & FINE V COMPACT FILTERS

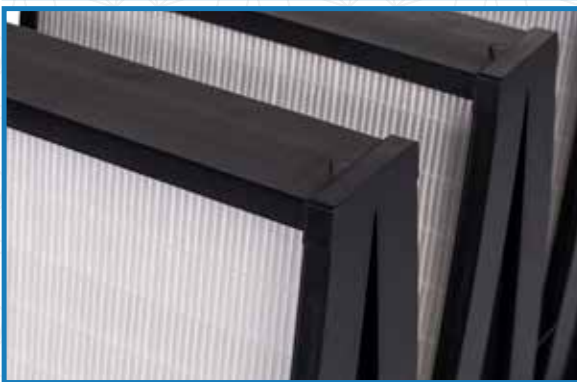

APPLICATIONS & ADVANTAGES

- ✓ Low initial pressure
- ✓ High dust holding capacity
- ✓ PU Gasket application upon request
- ✓ Low energy consumption
- ✓ High filtration area
- ✓ Ventilation and air conditioning plants for the separation of fine particles
- ✓ Pre filtration and main filtration in plants with high flow rate
- ✓ High efficiency filtration incritical applications
- ✓ Air purifications of smokes and pollens

PRODUCT CODE EXPLANATION

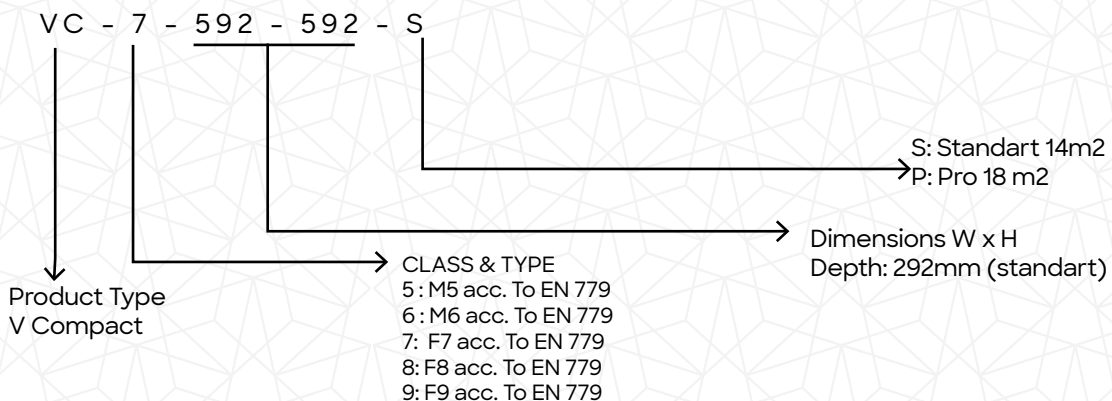

MEDIUM & FINE V COMPACT FILTERS

TECHNICAL SPECIFICATIONS

Filter Media	: Minipleat Micro Glass Fibre
Frame Material	: Plastic
Header Thickness	: 25 mm
Classification (EN779:2012)	: M5 - F9
Classification (ISO 16890)	: ePM1, ePM2,5 ePM10
Gasket	: Optional (Polyurethane / EPDM)
Seperator:	: Hotmelt
Sealant	: 2K Polyurethane
Final Pressure Drop	: 450 Pa
Max. Temperature	: 70 °C
Max. Moisture	: 90%



STD 14 M2



PRODUCT CODE	CLASS EN779	CLASS ISO16890	WIDTH (mm)	HEIGHT (mm)	DEPTH (mm)	FILTRATION AREA (m2)	NOMINAL AIR FLOW (m3/h)	INITIAL PRESSURE DROP (± 10% Pa)
VC-6-287-592-S	M6	ePM10 70%	287	592	292	7,00	1700	80
VC-6-490-592-S	M6	ePM10 70%	490	592	292	11,00	2800	80
VC-6-592-592-S	M6	ePM10 70%	592	592	292	14,00	3400	80
VC-7-287-592-S	F7	Epm2,5 70%	287	592	292	7,00	1700	100
VC-7-490-592-S	F7	ePM2,5 70%	490	592	292	11,00	2800	100
VC-7-592-592-S	F7	ePM2,5 70%	592	592	292	14,00	3400	100
VC-8-287-592-S	F8	ePM1 80%	287	592	292	7,00	1700	120
VC-8-490-592-S	F8	ePM1 80%	490	592	292	11,00	2800	120
VC-8-592-592-S	F8	ePM1 80%	592	592	292	14,00	3400	120
VC-9-287-592-S	F9	ePM1 85%	287	592	292	7,00	1700	135
VC-9-490-592-S	F9	ePM1 85%	490	592	292	11,00	2800	135
VC-9-592-592-S	F9	ePM1 85%	592	592	292	14,00	3400	135

PRO 18 M2



PRODUCT CODE	CLASS EN779	CLASS ISO16890	WIDTH (mm)	HEIGHT (mm)	DEPTH (mm)	FILTRATION AREA (m2)	NOMINAL AIR FLOW (m3/h)	INITIAL PRESSURE (± 10% Pa)
VC-6-287-592-P	M6	ePM10 70%	287	592	292	9,00	1700	65
VC-6-490-592-P	M6	ePM10 70%	490	592	292	15,00	2800	65
VC-6-592-592-P	M6	ePM10 70%	592	592	292	18,00	3400	65
VC-7-287-592-P	F7	ePM2,5 70%	287	592	292	9,00	1700	80
VC-7-490-592-P	F7	ePM2,5 70%	490	592	292	15,00	2800	80
VC-7-592-592-P	F7	ePM2,5 70%	592	592	292	18,00	3400	80
VC-8-287-592-P	F8	ePM1 80%	287	592	292	9,00	1700	95
VC-8-490-592-P	F8	ePM1 80%	490	592	292	15,00	2800	95
VC-8-592-592-P	F8	ePM1 80%	592	592	292	18,00	3400	95
VC-9-287-592-P	F9	ePM1 85%	287	592	292	9,00	1700	110
VC-9-490-592-P	F9	ePM1 85%	490	592	292	15,00	2800	110
VC-9-592-592-P	F9	ePM1 85%	592	592	292	18,00	3400	110

MEDIUM & FINE V BANK FILTERS



TECHNICAL SPECIFICATIONS

Filter Media : Minipleat Micro Glass Fibre
 Frame Material : Galvanized
 Classification (EN779:2012) : M5 - F9
 Classification (ISO 16890) : ePM1, ePM2,5 ePM10
 Gasket : Optional (Polyurethane / EPDM)
 Separator : Hotmelt
 Sealant : 2K Polyurethane
 Final Pressure Drop : 450 Pa
 Max. Temperature : 80 °C
 Max. Moisture : 90%



PRODUCT CODE	CLASS EN779	CLASS ISO16890	WIDTH (mm)	HEIGHT (mm)	DEPTH (mm)	FILTRATION AREA (m2)	NOMINAL AIR FLOW (m3/h)	INITIAL PRESSURE DROP (± 10% Pa)
VB-6-287-592	M6	ePM10 75%	287	592	292	9,00	2125	60
VB-6-490-592	M6	ePM10 75%	490	592	292	15,00	3500	60
VB-6-592-592	M6	ePM10 75%	592	592	292	18,00	4250	60
VB-7-287-592	F7	ePM1 60%	287	592	292	9,00	2125	75
VB-7-490-592	F7	ePM1 60%	490	592	292	15,00	3500	75
VB-7-592-592	F7	ePM1 60%	592	592	292	18,00	4250	75
VB-8-287-592	F8	ePM1 75%	287	592	292	9,00	2125	85
VB-8-490-592	F8	ePM1 75%	490	592	292	15,00	3500	85
VB-8-592-592	F8	ePM1 75%	592	592	292	18,00	4250	85
VB-9-287-592	F9	ePM1 85%	287	592	292	9,00	2125	100
VB-9-490-592	F9	ePM1 85%	490	592	292	15,00	3500	100
VB-9-592-592	F9	ePM1 85%	592	592	292	18,00	4250	100

PRODUCT CODE EXPLANATION

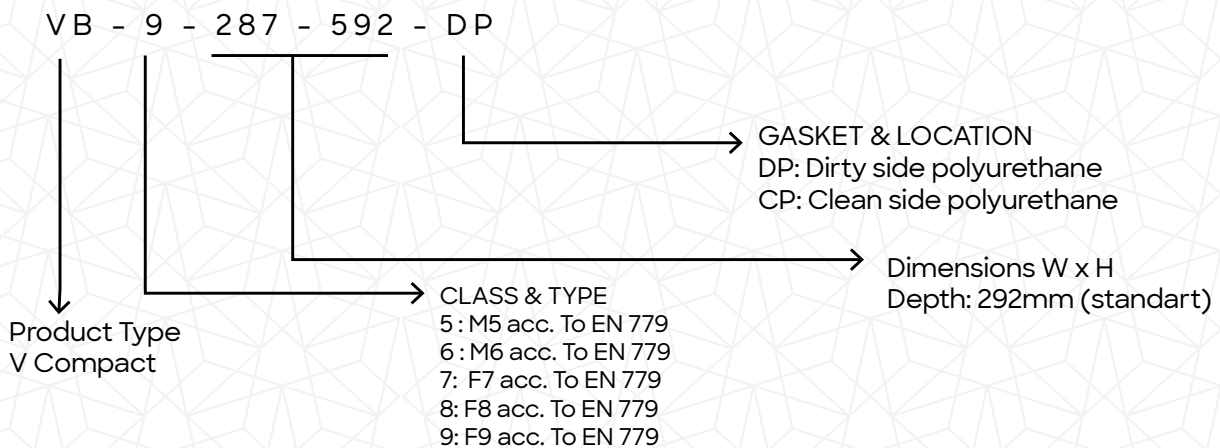

products

epa & hepa & ulpa filters



AFT FILTER®

EPA & HEPA

ULPA

FILTERS



HEPA TERMINAL FILTERS



- MDF (WOODEN FRAME
78 MM DEPTH
149 MM DEPTH
- ALUMINIUM FRAME
69 MM DEPTH
78 MM DEPTH
80 MM DEPTH WITH GEL SEAL
149 MM DEPTH

HIGH FLOW FILTERS 292 MM



- MDF (WOODEN) FRAME
- ALUMINIUM FRAME
- GALVANISED STEEL FRAME

V COMPACT FILTERS



V BANK FILTERS



HOODED TYPE FILTERS

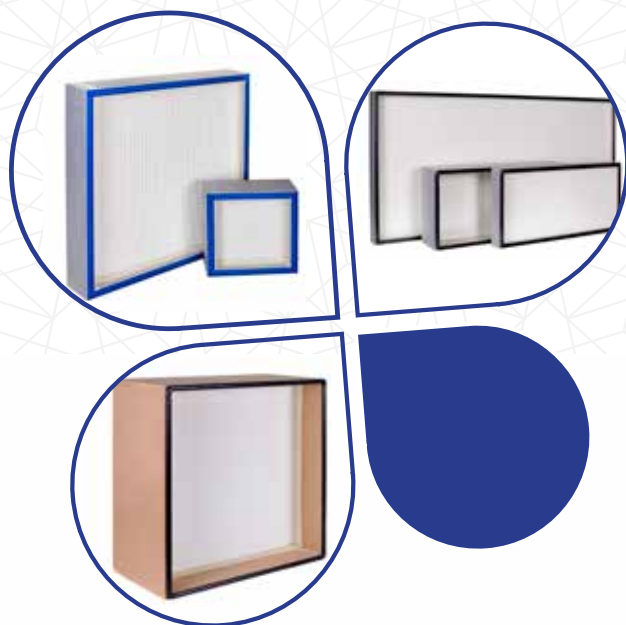

EPA & HEPA & ULPA TERMINAL FILTERS



MDF WOODEN FRAME
78 MM / 149 MM



ALUMINIUM FRAME
69 MM / 78 MM / 149 MM



GEL SEAL ALUMINIUM FRAME
80 MM

APPLICATIONS & ADVANTAGES

- ✓ Lightweight construction
- ✓ High filtration surface
- ✓ Low pressure drop
- ✓ Continuous gasket enables leak free filtration
- ✓ Ventilation and air conditioning in the electronics, pharmaceutical and food industry
- ✓ Particulate control in hospitals, laboratories, clean room processing, data centres
- ✓ Separation of viruses, bacterial, aerosol and toxic dust

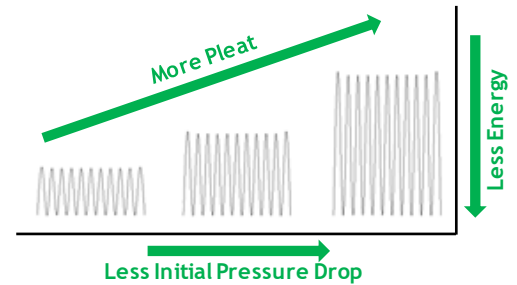

PRODUCT CODE EXPLANATION

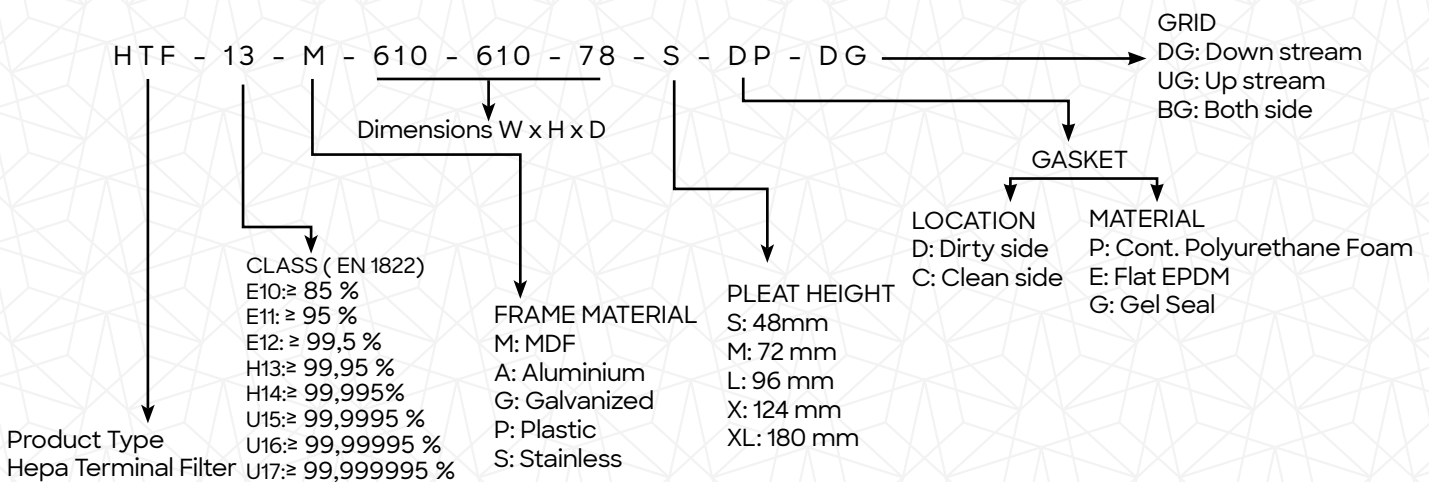

HEPA TERMINAL FILTERS- 78 MM MDF FRAME

**TECHNICAL SPECIFICATIONS**

Filter Media	: Minipleat Micro Glass Fibre
Frame Material	: MDF
Classification (EN1822)	: E10 - U17
Gasket	: Cont. Round PU / Flat Epdm
Seperator	: Hotmelt
Sealant	: 2K Polyurethane
Final Pressure Drop	: 600 Pa
Max. Temperature	: 80 °C
Max. Moisture	: 90%
Rated Face Velocity	: 0,45 m/s



PRODUCT CODE	CLASS EN1822	WIDTH (mm)	HEIGHT (mm)	DEPTH (mm)	FILTRATION AREA (m2)	NOMINAL AIR FLOW (m3/h)	INITIAL PRESSURE DROP (± 10% Pa)
HTF-10-M-203-203-78-S-DP	E10	203	203	78	1,10	75	75
HTF-10-M-305-305-78-S-DP	E10	305	305	78	2,45	150	65
HTF-10-M-305-610-78-S-DP	E10	305	610	78	4,90	300	65
HTF-10-M-457-457-78-S-DP	E10	457	457	78	5,50	340	65
HTF-10-M-535-535-78-S-DP	E10	535	535	78	7,55	465	65
HTF-10-M-575-575-78-S-DP	E10	575	575	78	8,70	535	65
HTF-10-M-610-610-78-S-DP	E10	610	610	78	9,80	600	65
HTF-10-M-610-762-78-S-DP	E10	610	762	78	12,25	750	65
HTF-10-M-610-915-78-S-DP	E10	610	915	78	14,70	900	65
HTF-10-M-610-1220-78-S-DP	E10	610	1220	78	19,60	1200	65
HTF-10-M-610-1830-78-S-DP	E10	610	1830	78	29,40	1800	65
HTF-13-M-203-203-78-S-DP	H13	203	203	78	1,10	75	65
HTF-13-M-305-305-78-S-DP	H13	305	305	78	2,45	150	100
HTF-13-M-305-610-78-S-DP	H13	305	610	78	4,90	300	100
HTF-13-M-457-457-78-S-DP	H13	457	457	78	5,50	340	100
HTF-13-M-535-535-78-S-DP	H13	535	535	78	7,55	465	100
HTF-13-M-575-575-78-S-DP	H13	575	575	78	8,70	535	100
HTF-13-M-610-610-78-S-DP	H13	610	610	78	9,80	600	100
HTF-13-M-610-762-78-S-DP	H13	610	762	78	12,25	750	100
HTF-13-M-610-915-78-S-DP	H13	610	915	78	14,70	900	100
HTF-13-M-610-1220-78-S-DP	H13	610	1220	78	19,60	1200	100
HTF-13-M-610-1830-78-S-DP	H13	610	1830	78	29,40	1800	100
HTF-14-M-203-203-78-S-DP	H14	203	203	78	1,10	75	100
HTF-14-M-305-305-78-S-DP	H14	305	305	78	2,45	150	125
HTF-14-M-305-610-78-S-DP	H14	305	610	78	4,90	300	125
HTF-14-M-457-457-78-S-DP	H14	457	457	78	5,50	340	125
HTF-14-M-535-535-78-S-DP	H14	535	535	78	7,55	465	125
HTF-14-M-575-575-78-S-DP	H14	575	575	78	8,70	535	125
HTF-14-M-610-610-78-S-DP	H14	610	610	78	9,80	600	125
HTF-14-M-610-762-78-S-DP	H14	610	762	78	12,25	750	125
HTF-14-M-610-915-78-S-DP	H14	610	915	78	14,70	900	125
HTF-14-M-610-1220-78-S-DP	H14	610	1220	78	19,60	1200	125
HTF-14-M-610-1830-78-S-DP	H14	610	1830	78	29,40	1800	125

HEPA TERMINAL FILTERS- 149 MM MDF FRAME

**TECHNICAL SPECIFICATIONS**

Filter Media	: Minipleat Micro Glass Fibre
Frame Material	: MDF
Classification (EN1822):	: E10 - U17
Gasket	: Cont. Round PU / Flat Epdm
Seperator:	: Hotmelt
Sealant	: 2K Polyurethane
Final Pressure Drop	: 600 Pa
Max. Temperature	: 80 °C
Max. Moisture	: 90%



PRODUCT CODE	CLASS EN1822	WIDTH (mm)	HEIGHT (mm)	DEPTH (mm)	FILTRATION AREA (m2) 48 / 72 / 96 mm (S) (M) (L)	NOMINAL AIR FLOW (m3/h)	INITIAL PRESSURE DROP(± 10% Pa)
HTF-10-M-203-203-149-X-DP	E10	203	203	149	1,10 / 1,65 / 2,20	75	80 / 50 / 40
HTF-10-M-305-305-149-X-DP	E10	305	305	149	2,45 / 3,68 / 4,90	150	80 / 50 / 40
HTF-10-M-305-610-149-X-DP	E10	305	610	149	4,90 / 7,35 / 9,80	300	80 / 50 / 40
HTF-10-M-457-457-149-X-DP	E10	457	457	149	5,50 / 8,25 / 11,00	340	80 / 50 / 40
HTF-10-M-535-535-149-X-DP	E10	535	535	149	7,55 / 11,30 / 15,08	465	80 / 50 / 40
HTF-10-M-575-575-149-X-DP	E10	575	575	149	8,70 / 13,05 / 17,40	535	80 / 50 / 40
HTF-10-M-610-610-149-X-DP	E10	610	610	149	9,80 / 14,70 / 19,60	600	80 / 50 / 40
HTF-10-M-610-762-149-X-DP	E10	610	762	149	12,25 / 18,38 / 24,50	750	80 / 50 / 40
HTF-10-M-610-915-149-X-DP	E10	610	915	149	14,70 / 22,05 / 29,40	900	80 / 50 / 40
HTF-10-M-610-1220-149-X-DP	E10	610	1220	149	19,60 / 29,40 / 39,20	1200	80 / 50 / 40
HTF-10-M-610-1830-149-X-DP	E10	610	1830	149	29,40 / 44,10 / 58,80	1800	80 / 50 / 40
HTF-13-M-203-203-149-X-DP	H13	203	203	149	1,10 / 1,65 / 2,20	75	100 / 70 / 60
HTF-13-M-305-305-149-X-DP	H13	305	305	149	2,45 / 3,68 / 4,90	150	100 / 70 / 60
HTF-13-M-305-610-149-X-DP	H13	305	610	149	4,90 / 7,35 / 9,80	300	100 / 70 / 60
HTF-13-M-457-457-149-X-DP	H13	457	457	149	5,50 / 8,25 / 11,00	340	100 / 70 / 60
HTF-13-M-535-535-149-X-DP	H13	535	535	149	7,55 / 11,30 / 15,08	465	100 / 70 / 60
HTF-13-M-575-575-149-X-DP	H13	575	575	149	8,70 / 13,05 / 17,40	535	100 / 70 / 60
HTF-13-M-610-610-149-X-DP	H13	610	610	149	9,80 / 14,70 / 19,60	600	100 / 70 / 60
HTF-13-M-610-762-149-X-DP	H13	610	762	149	12,25 / 18,38 / 24,50	750	100 / 70 / 60
HTF-13-M-610-915-149-X-DP	H13	610	915	149	14,70 / 22,05 / 29,40	900	100 / 70 / 60
HTF-13-M-610-1220-149-X-DP	H13	610	1220	149	19,60 / 29,40 / 39,20	1200	100 / 70 / 60
HTF-13-M-610-1830-149-X-DP	H13	610	1830	149	29,40 / 44,10 / 58,80	1800	100 / 70 / 60
HTF-14-M-203-203-149-X-DP	H14	203	203	149	1,10 / 1,65 / 2,20	75	125 / 75 / 65
HTF-14-M-305-305-149-X-DP	H14	305	305	149	2,45 / 3,68 / 4,90	150	125 / 75 / 65
HTF-14-M-305-610-149-X-DP	H14	305	610	149	4,90 / 7,35 / 9,80	300	125 / 75 / 65
HTF-14-M-457-457-149-X-DP	H14	457	457	149	5,50 / 8,25 / 11,00	340	125 / 75 / 65
HTF-14-M-535-535-149-X-DP	H14	535	535	149	7,55 / 11,30 / 15,08	465	125 / 75 / 65
HTF-14-M-575-575-149-X-DP	H14	575	575	149	8,70 / 13,05 / 17,40	535	125 / 75 / 65
HTF-14-M-610-610-149-X-DP	H14	610	610	149	9,80 / 14,70 / 19,60	600	125 / 75 / 65
HTF-14-M-610-762-149-X-DP	H14	610	762	149	12,25 / 18,38 / 24,50	750	125 / 75 / 65
HTF-14-M-610-915-149-X-DP	H14	610	915	149	14,70 / 22,05 / 29,40	900	125 / 75 / 65
HTF-14-M-610-1220-149-X-DP	H14	610	1220	149	19,60 / 29,40 / 39,20	1200	125 / 75 / 65
HTF-14-M-610-1830-149-X-DP	H14	610	1830	149	29,40 / 44,10 / 58,80	1800	125 / 75 / 65

HEPA TERMINAL FILTERS – 69 MM ALUMINIUM FRAME

**TECHNICAL SPECIFICATIONS**

Filter Media	: Minipleat Micro Glass Fibre
Frame Material	: Aluminium Steel
Classification (EN1822)	: E10 – U17
Gasket	: Cont. Round Pu / Flat Epdm
Seperator	: Hotmelt
Sealant	: 2K Polyurethane
Final Pressure Drop	: 600 Pa
Max. Temperature:	: 80 °C
Max. Moisture	: 90%
Rated Face Velocity	: 0,45 m/s



PRODUCT CODE	CLASS EN1822	WIDTH (mm)	HEIGHT (mm)	DEPTH (mm)	FILTRATION AREA (m ²)	NOMINAL AIR FLOW (m ³ /h)	INITIAL PRESSURE DROP (± 10% Pa)
HTF-10-A-203-203-69-S-DP-DG	E 10	203	203	78	1,10	75	65
HTF-10-A-305-305-69-S-DP-DG	E 10	305	305	78	2,45	150	65
HTF-10-A-305-610-69-S-DP-DG	E 10	305	610	78	4,90	300	65
HTF-10-A-457-457-69-S-DP-DG	E 10	457	457	78	5,50	340	65
HTF-10-A-535-535-69-S-DP-DG	E 10	535	535	78	7,55	465	65
HTF-10-A-575-575-69-S-DP-DG	E 10	575	575	78	8,70	535	65
HTF-10-A-610-610-69-S-DP-DG	E 10	610	610	78	9,80	600	65
HTF-10-A-610-762-69-S-DP-DG	E 10	610	762	78	12,25	750	65
HTF-10-A-610-915-69-S-DP-DG	E 10	610	915	78	14,70	900	65
HTF-10-A-610-1220-69-S-DP-DG	E 10	610	1220	78	19,60	1200	65
HTF-10-A-610-1830-69-S-DP-DG	E 10	610	1830	78	29,40	1800	65
HTF-13-A-203-203-69-S-DP-DG	H 13	203	203	78	1,10	75	100
HTF-13-A-305-305-69-S-DP-DG	H 13	305	305	78	2,45	150	100
HTF-13-A-305-610-69-S-DP-DG	H 13	305	610	78	4,90	300	100
HTF-13-A-457-457-69-S-DP-DG	H 13	457	457	78	5,50	340	100
HTF-13-A-535-535-69-S-DP-DG	H 13	535	535	78	7,55	465	100
HTF-13-A-575-575-69-S-DP-DG	H 13	575	575	78	8,70	535	100
HTF-13-A-610-610-69-S-DP-DG	H 13	610	610	78	9,80	600	100
HTF-13-A-610-762-69-S-DP-DG	H 13	610	762	78	12,25	750	100
HTF-13-A-610-915-69-S-DP-DG	H 13	610	915	78	14,70	900	100
HTF-13-A-610-1220-69-S-DP-DG	H 13	610	1220	78	19,60	1200	100
HTF-13-A-610-1830-69-S-DP-DG	H 13	610	1830	78	29,40	1800	100
HTF-14-A-203-203-69-S-DP-DG	H 14	203	203	78	1,10	75	125
HTF-14-A-305-305-69-S-DP-DG	H 14	305	305	78	2,45	150	125
HTF-14-A-305-610-69-S-DP-DG	H 14	305	610	78	4,90	300	125
HTF-14-A-457-457-69-S-DP-DG	H 14	457	457	78	5,50	340	125
HTF-14-A-535-535-69-S-DP-DG	H 14	535	535	78	7,55	465	125
HTF-14-A-575-575-69-S-DP-DG	H 14	575	575	78	8,70	535	125
HTF-14-A-610-610-69-S-DP-DG	H 14	610	610	78	9,80	600	125
HTF-14-A-610-762-69-S-DP-DG	H 14	610	762	78	12,25	750	125
HTF-14-A-610-915-69-S-DP-DG	H 14	610	915	78	14,70	900	125
HTF-14-A-610-1220-69-S-DP-DG	H 14	610	1220	78	19,60	1200	125
HTF-14-A-610-1830-69-S-DP-DG	H 14	610	1830	78	29,40	1800	125

HEPA TERMINAL FILTERS- 78 MM ALUMINIUM FRAME

TECHNICAL SPECIFICATIONS

Filter Media	: Minipleat Micro Glass Fibre
Frame Material	: Aluminium Steel
Classification (EN1822)	: E10 - U17
Gasket	: Cont. Round Pu / Flat Epdm
Seperator	: Hotmelt
Sealant	: 2K Polyurethane
Final Pressure Drop	: 600 Pa
Max. Temperature	: 80 °C
Max. Moisture	: 90%
Rated Face Velocity	: 0,45 m/s

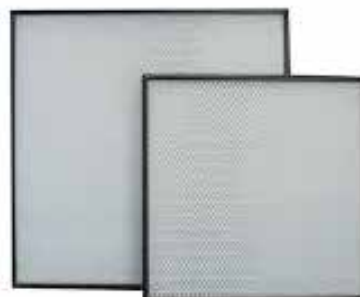

PRODUCT CODE	CLASS EN1822	WIDTH (mm)	HEIGHT (mm)	DEPTH (mm)	FILTRATION AREA (m2)	NOMINAL AIR FLOW (m3/h)	INITIAL PRESSURE DROP (± 10% Pa)
HTF-10-A-203-203-78-S-DP-DG	E10	203	203	78	1,10	75	65
HTF-10-A-305-305-78-S-DP-DG	E10	305	305	78	2,45	150	65
HTF-10-A-305-610-78-S-DP-DG	E10	305	610	78	4,90	300	65
HTF-10-A-457-457-78-S-DP-DG	E10	457	457	78	5,50	340	65
HTF-10-A-535-535-78-S-DP-DG	E10	535	535	78	7,55	465	65
HTF-10-A-575-575-78-S-DP-DG	E10	575	575	78	8,70	535	65
HTF-10-A-610-610-78-S-DP-DG	E10	610	610	78	9,80	600	65
HTF-10-A-610-762-78-S-DP-DG	E10	610	762	78	12,25	750	65
HTF-10-A-610-915-78-S-DP-DG	E10	610	915	78	14,70	900	65
HTF-10-A-610-1220-78-S-DP-DG	E10	610	1220	78	19,60	1200	65
HTF-10-A-610-1830-78-S-DP-DG	E10	610	1830	78	29,40	1800	65
HTF-13-A-203-203-78-S-DP-DG	H13	203	203	78	1,10	75	100
HTF-13-A-305-305-78-S-DP-DG	H13	305	305	78	2,45	150	100
HTF-13-A-305-610-78-S-DP-DG	H13	305	610	78	4,90	300	100
HTF-13-A-457-457-78-S-DP-DG	H13	457	457	78	5,50	340	100
HTF-13-A-535-535-78-S-DP-DG	H13	535	535	78	7,55	465	100
HTF-13-A-575-575-78-S-DP-DG	H13	575	575	78	8,70	535	100
HTF-13-A-610-610-78-S-DP-DG	H13	610	610	78	9,80	600	100
HTF-13-A-610-762-78-S-DP-DG	H13	610	762	78	12,25	750	100
HTF-13-A-610-915-78-S-DP-DG	H13	610	915	78	14,70	900	100
HTF-13-A-610-1220-78-S-DP-DG	H13	610	1220	78	19,60	1200	100
HTF-13-A-610-1830-78-S-DP-DG	H13	610	1830	78	29,40	1800	100
HTF-14-A-203-203-78-S-DP-DG	H14	203	203	78	1,10	75	125
HTF-14-A-305-305-78-S-DP-DG	H14	305	305	78	2,45	150	125
HTF-14-A-305-610-78-S-DP-DG	H14	305	610	78	4,90	300	125
HTF-14-A-457-457-78-S-DP-DG	H14	457	457	78	5,50	340	125
HTF-14-A-535-535-78-S-DP-DG	H14	535	535	78	7,55	465	125
HTF-14-A-575-575-78-S-DP-DG	H14	575	575	78	8,70	535	125
HTF-14-A-610-610-78-S-DP-DG	H14	610	610	78	9,80	600	125
HTF-14-A-610-762-78-S-DP-DG	H14	610	762	78	12,25	750	125
HTF-14-A-610-915-78-S-DP-DG	H14	610	915	78	14,70	900	125
HTF-14-A-610-1220-78-S-DP-DG	H14	610	1220	78	19,60	1200	125
HTF-14-A-610-1830-78-S-DP-DG	H14	610	1830	78	29,40	1800	125

HEPA TERMINAL FILTERS – 149 MM ALUMINIUM FRAME **TECHNICAL SPECIFICATIONS**

Filter Media	: Minipleat Micro Glass Fibre
Frame Material:	: Aluminium Steel
Classification (EN1822)	: E10 – U17
Gasket	: Cont. Round Pu / Flat Epdm
Seperator	: Hotmelt
Sealant	: 2K Polyurethane
Final Pressure Drop	: 600 Pa
Max. Temperature	: 80 °C
Max. Moisture	: 90%



PRODUCT CODE	CLASS EN1822	WIDTH (mm)	HEIGHT (mm)	DEPTH (mm)	FILTRATION AREA (m2)			NOMINAL AIR FLOW (m3/h)	INITIAL PRESSURE DROP (± 10% Pa)
					48 / 72 / 96 mm	(S)	(M)		
HTF-10-A-203-203-149-X-DP	E 10	203	203	149	1,10 / 1,65 / 2,20			75	65 / 50 / 40
HTF-10-A-305-305-149-X-DP	E 10	305	305	149	2,45 / 3,68 / 4,90			150	65 / 50 / 40
HTF-10-A-305-610-149-X-DP	E 10	305	610	149	4,90 / 7,35 / 9,80			300	65 / 50 / 40
HTF-10-A-457-457-149-X-DP	E 10	457	457	149	5,50 / 8,25 / 11,00			340	65 / 50 / 40
HTF-10-A-535-535-149-X-DP	E 10	535	535	149	7,54 / 11,30 / 15,08			465	65 / 50 / 40
HTF-10-A-575-575-149-X-DP	E 10	575	575	149	8,70 / 13,05 / 17,40			535	65 / 50 / 40
HTF-10-A-610-610-149-X-DP	E 10	610	610	149	9,80 / 14,70 / 19,60			600	65 / 50 / 40
HTF-10-A-610-762-149-X-DP	E 10	610	762	149	12,25 / 18,38 / 24,50			750	65 / 50 / 40
HTF-10-A-610-915-149-X-DP	E 10	610	915	149	14,70 / 22,05 / 29,40			900	65 / 50 / 40
HTF-10-A-610-1220-149-X-DP	E 10	610	1220	149	19,60 / 29,40 / 39,20			1200	65 / 50 / 40
HTF-10-A-610-1830-149-X-DP	E 10	610	1830	149	29,40 / 44,10 / 58,80			1800	65 / 50 / 40
HTF-13-A-203-203-149-X-DP	H 13	203	203	149	1,10 / 1,65 / 2,20			75	100 / 70 / 60
HTF-13-A-305-305-149-X-DP	H 13	305	305	149	2,45 / 3,68 / 4,90			150	100 / 70 / 60
HTF-13-A-305-610-149-X-DP	H 13	305	610	149	4,90 / 7,35 / 9,80			300	100 / 70 / 60
HTF-13-A-457-457-149-X-DP	H 13	457	457	149	5,50 / 8,25 / 11,00			340	100 / 70 / 60
HTF-13-A-535-535-149-X-DP	H 13	535	535	149	7,54 / 11,30 / 15,08			465	100 / 70 / 60
HTF-13-A-575-575-149-X-DP	H 13	575	575	149	8,70 / 13,05 / 17,40			535	100 / 70 / 60
HTF-13-A-610-610-149-X-DP	H 13	610	610	149	9,80 / 14,70 / 19,60			600	100 / 70 / 60
HTF-13-A-610-762-149-X-DP	H 13	610	762	149	12,25 / 18,38 / 24,50			750	100 / 70 / 60
HTF-13-A-610-915-149-X-DP	H 13	610	915	149	14,70 / 22,05 / 29,40			900	100 / 70 / 60
HTF-13-A-610-1220-149-X-DP	H 13	610	1220	149	19,60 / 29,40 / 39,20			1200	100 / 70 / 60
HTF-13-A-610-1830-149-X-DP	H 13	610	1830	149	29,40 / 44,10 / 58,80			1800	100 / 70 / 60
HTF-14-A-203-203-149-X-DP	H 14	203	203	149	1,10 / 1,65 / 2,20			75	125 / 85 / 75
HTF-14-A-305-305-149-X-DP	H 14	305	305	149	2,45 / 3,68 / 4,90			150	125 / 85 / 75
HTF-14-A-305-610-149-X-DP	H 14	305	610	149	4,90 / 7,35 / 9,80			300	125 / 85 / 75
HTF-14-A-457-457-149-X-DP	H 14	457	457	149	5,50 / 8,25 / 11,00			340	125 / 85 / 75
HTF-14-A-535-535-149-X-DP	H 14	535	535	149	7,54 / 11,30 / 15,08			465	125 / 85 / 75
HTF-14-A-575-575-149-X-DP	H 14	575	575	149	8,70 / 13,05 / 17,40			535	125 / 85 / 75
HTF-14-A-610-610-149-X-DP	H 14	610	610	149	9,80 / 14,70 / 19,60			600	125 / 85 / 75
HTF-14-A-610-762-149-XX-DP	H 14	610	762	149	12,25 / 18,38 / 24,50			750	125 / 85 / 75
HTF-14-A-610-915-149-XX-DP	H 14	610	915	149	14,70 / 22,05 / 29,40			900	125 / 85 / 75
HTF-14-A-610-1220-149-XX-DP	H 14	610	1220	149	19,60 / 29,40 / 39,20			1200	125 / 85 / 75
HTF-14-A-610-1830-149-XX-DP	H 14	610	1830	149	29,40 / 44,10 / 58,80			1800	125 / 85 / 75

HEPA TERMINAL FILTERS-GEL SEAL 80 MM ALUMINIUM FRAME
TECHNICAL SPECIFICATIONS

Filter Media	: Minipleat Micro Glass Fibre
Frame Material	: Aluminium Steel
Classification (EN1822)	: E10 - U17
Gasket	: Gel Seal
Separator	: Hotmelt
Sealant	: 2K Polyurethane
Final Pressure Drop	: 600 Pa
Max. Temperature	: 80 °C
Max. Moisture	: 90%



Gel fluid seal guarantee a leak free design when assembled with a knife edge housing

PRODUCT CODE	CLASS EN1822	WIDTH (mm)	HEIGHT (mm)	DEPTH (mm)	FILTRATION AREA (m ²)	NOMINAL AIR FLOW (m ³ /h)	INITIAL PRESSURE DROP (± 10% Pa)
HTF-13-A-203-203-80-S-DG-BG	H 13	203	203	80	1,10	75	100
HTF-13-A-305-305-80-S-DG-BG	H 13	305	305	80	2,45	150	100
HTF-13-A-305-610-80-S-DG-BG	H 13	305	610	80	4,90	300	100
HTF-13-A-457-457-80-S-DG-BG	H 13	457	457	80	5,50	340	100
HTF-13-A-535-535-80-S-DG-BG	H 13	535	535	80	7,55	465	100
HTF-13-A-575-575-80-S-DG-BG	H 13	575	575	80	8,70	535	100
HTF-13-A-610-610-80-S-DG-BG	H 13	610	610	80	9,80	600	100
HTF-13-A-610-762-80-S-DG-BG	H 13	610	762	80	12,25	750	100
HTF-13-A-610-915-80-S-DG-BG	H 13	610	915	80	14,70	900	100
HTF-13-A-610-1220-80-S-DG-BG	H 13	610	1220	80	19,60	1200	100
HTF-13-A-610-1830-80-S-DG-BG	H 13	610	1830	80	29,40	1800	100
HTF-14-A-203-203-80-S-DG-BG	H 14	203	203	80	1,10	75	125
HTF-14-A-305-305-80-S-DG-BG	H 14	305	305	80	2,45	150	125
HTF-14-A-305-610-80-S-DG-BG	H 14	305	610	80	4,90	300	125
HTF-14-A-457-457-80-S-DG-BG	H 14	457	457	80	5,50	340	125
HTF-14-A-535-535-80-S-DG-BG	H 14	535	535	80	7,55	465	125
HTF-14-A-575-575-80-S-DG-BG	H 14	575	575	80	8,70	535	125
HTF-14-A-610-610-80-S-DG-BG	H 14	610	610	80	9,80	600	125
HTF-14-A-610-762-80-S-DG-BG	H 14	610	762	80	12,25	750	125
HTF-14-A-610-915-80-S-DG-BG	H 14	610	915	80	14,70	900	125
HTF-14-A-610-1220-80-S-DG-BG	H 14	610	1220	80	19,60	1200	125
HTF-14-A-610-1830-80-S-DG-BG	H 14	610	1830	80	29,40	1800	125
HTF-15-A-203-203-80-S-DG-BG	U 15	203	203	80	1,10	75	145
HTF-15-A-305-305-80-S-DG-BG	U 15	305	305	80	2,45	150	145
HTF-15-A-305-610-80-S-DG-BG	U 15	305	610	80	4,90	300	145
HTF-15-A-457-457-80-S-DG-BG	U 15	457	457	80	5,50	340	145
HTF-15-A-535-535-80-S-DG-BG	U 15	535	535	80	7,55	465	145
HTF-15-A-575-575-80-S-DG-BG	U 15	575	575	80	8,70	535	145
HTF-15-A-610-610-80-S-DG-BG	U 15	610	610	80	9,80	600	145
HTF-15-A-610-762-80-S-DG-BG	U 15	610	762	80	12,25	750	145
HTF-15-A-610-915-80-S-DG-BG	U 15	610	915	80	14,70	900	145
HTF-15-A-610-1220-80-S-DG-BG	U 15	610	1220	80	19,60	1200	145
HTF-15-A-610-1830-80-S-DG-BG	U 15	610	1830	80	29,40	1800	145

HIGH FLOW FILTERS 292 MM



MDF WOODEN FRAME /292 MM



ALUMINIUM FRAME /292 MM



GALVANIZED FRAME /292 MM

APPLICATIONS & ADVANTAGES

- ✓ Lightweight construction
- ✓ High filtration surface
- ✓ Low pressure drop
- ✓ Continuous gasket enables leak free filtration
- ✓ Ventilation and air conditioning in the electronics, pharmaceutical and food industry
- ✓ Particulate control in hospitals, laboratories, clean room processing, data centres
- ✓ Separation of viruses, bacterial, aerosol and toxic dust

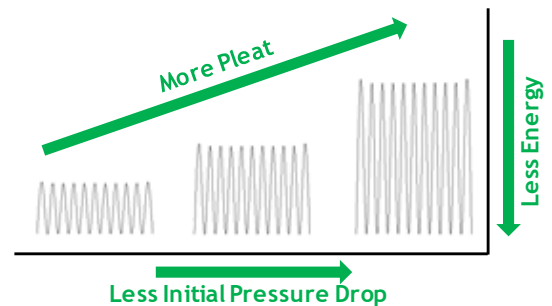

PRODUCT CODE EXPLANATION

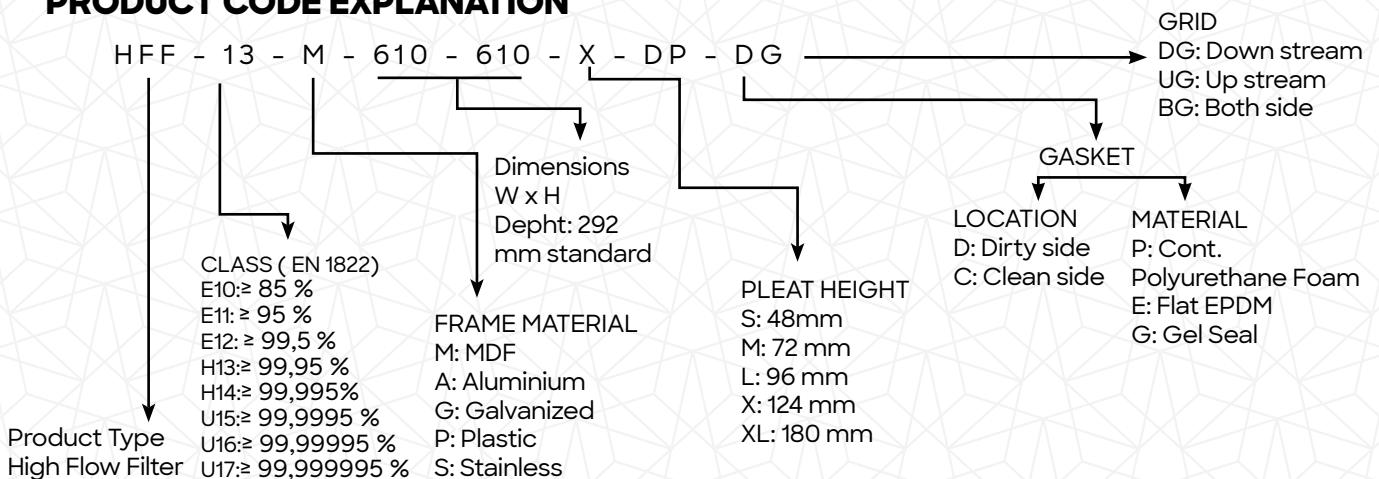



HIGH FLOW FILTERS-292 MM MDF FRAME



TECHNICAL SPECIFICATIONS

Filter Media : Minipleat Micro Glass Fibre
 Frame Material : MDF
 Classification (EN1822): E10 - U17
 Gasket : Cont. Round Pu / Flat Epdm
 Separator : Hotmelt
 Sealant : 2K Polyur ethane
 Final Pressure Drop : 600 Pa
 Max. Temperature : 80 °C
 Max. Moisture : 90%



PRODUCT CODE	CLASS EN1822	WIDTH (mm)	HEIGHT (mm)	DEPTH (mm)	FILTRATION AREA (m2)	NOMINAL AIR FLOW (m3/h)	INITIAL PRESSURE DROP (± 10% Pa)
HFF-10-M-305-305-X-DP	E 10	305	305	292	5,25	500	210
HFF-10-M-305-610-X-DP	E 10	305	610	292	10,50	1000W	210
HFF-10-M-610-610-X-DP	E 10	610	610	292	21,00	2000	210
HFF-10-M-305-305-X-DP	H 13	305	305	292	5,25	500	250
HFF-13-M-305-610-X-DP	H 13	305	610	292	10,50	1000	250
HFF-13-M-610-610-X-DP	H 13	610	610	292	21,00	2000	250
HFF-14-M-305-305-X-DP	H 14	305	305	292	5,25	500	270
HFF-14-M-305-610-X-DP	H 14	305	610	292	10,50	1000	270
HFF-14-M-610-610-X-DP	H 14	610	610	292	21,00	2000	270
HFF-10-M-305-305-XL-DP	E 10	305	305	292	6,75	750	210
HFF-10-M-305-610-XL-DP	E 10	305	610	292	13,50	1500	210
HFF-10-M-610-610-XL-DP	E 10	610	610	292	27,00	3000	210
HFF-10-M-305-305-XL-DP	H 13	305	305	292	6,75	750	250
HFF-13-M-305-610-XL-DP	H 13	305	610	292	13,50	1500	250
HFF-13-M-610-610-XL-DP	H 13	610	610	292	27,00	3000	250
HFF-14-M-305-305-XL-DP	H 14	305	305	292	6,75	750	270
HFF-14-M-305-610-XL-DP	H 14	305	610	292	13,50	1500	270
HFF-14-M-610-610-XL-DP	H 14	610	610	292	27,00	3000	270

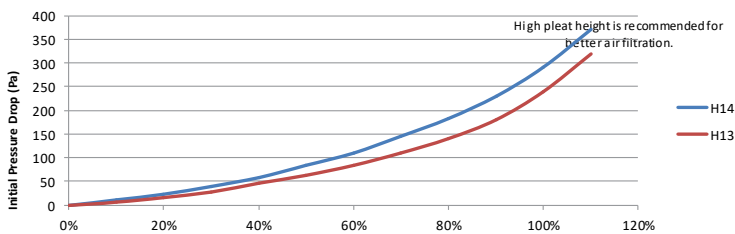

Available Pleat Height

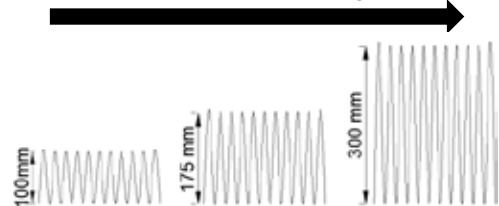

HIGH FLOW FILTERS-292 MM ALUMINIUM FRAME

TECHNICAL SPECIFICATIONS

Filter Media	: Minipleat Micro Glass Fibre
Frame Material	: Aluminium Steel
Classification (EN1822)	: E10 – U17
Gasket	: Cont. Round Pu / Flat Epdm
Seperator	: Hotmelt
Sealant	: 2K Polyurethane
Final Pressure Drop	: 600 Pa
Max. Temperature	: 80 °C
Max. Moisture	: 90%



PRODUCT CODE	CLASS EN1822	WIDTH (mm)	HEIGHT (mm)	DEPTH (mm)	FILTRATION AREA (m2)	NOMINAL AIR FLOW (m3/h)	INITIAL PRESSURE DROP (± 10% Pa)
HFF-10-A-305-305-X-DP-DG	E 10	305	305	292	5,25	500	210
HFF-10-A-305-610-X-DP-DG	E 10	305	610	292	10,50	1000	210
HFF-10-A-610-610-X-DP-DG	E 10	610	610	292	21,00	2000	210
HFF-10-A-305-305-X-DP-DG	H 13	305	305	292	5,25	500	250
HFF-13-A-305-610-X-DP-DG	H 13	305	610	292	10,50	1000	250
HFF-13-A-610-610-X-DP-DG	H 13	610	610	292	21,00	2000	250
HFF-14-A-305-305-X-DP-DG	H 14	305	305	292	5,25	500	270
HFF-14-A-305-610-X-DP-DG	H 14	305	610	292	10,50	1000	270
HFF-14-A-610-610-X-DP-DG	H 14	610	610	292	21,00	2000	270
HFF-10-A-305-305-XL-DP-DG	E 10	305	305	292	6,75	750	210
HFF-10-A-305-610-XL-DP-DG	E 10	305	610	292	13,50	1500	210
HFF-10-A-610-610-XL-DP-DG	E 10	610	610	292	27,00	3000	210
HFF-10-A-305-305-XL-DP-DG	H 13	305	305	292	6,75	750	250
HFF-13-A-305-610-XL-DP-DG	H 13	305	610	292	13,50	1500	250
HFF-13-A-610-610-XL-DP-DG	H 13	610	610	292	27,00	3000	250
HFF-14-A-305-305-XL-DP-DG	H 14	305	305	292	6,75	750	270
HFF-14-A-305-610-XL-DP-DG	H 14	305	610	292	13,50	1500	270
HFF-14-A-610-610-XL-DP-DG	H 14	610	610	292	27,00	3000	270

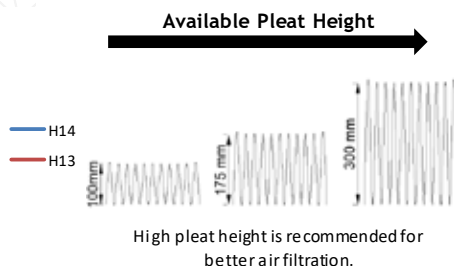
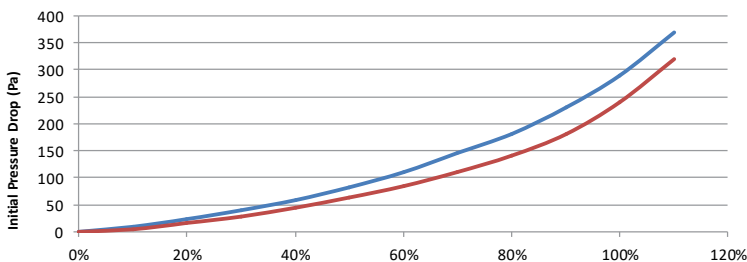

HIGH FLOW FILTERS-292 MM GALVANIZED FRAME

TECHNICAL SPECIFICATIONS

Filter Media : Minipleat Micro Glass Fibre
 Frame Material : Galvanized Steel
 Classification (EN1822): E10 - U17
 Gasket : Cont. Round Pu / Flat Epdm
 Seperator : Hotmelt
 Sealant : 2K Polyur ethane
 Final Pressure Drop : 600 Pa
 Max. Temperature : 80 °C
 Max. Moisture : 90%



PRODUCT CODE	CLASS EN1822	WIDTH (mm)	HEIGHT (mm)	DEPTH (mm)	FILTRATION AREA (m2)	NOMINAL AIR FLOW (m3/h)	INITIAL PRESSURE DROP (± 10% Pa)
HFF-10-G-305-305-X-DP-DG	E 10	305	305	292	5,25	500	210
HFF-10-G-305-610-X-DP-DG	E 10	305	610	292	10,50	1000	210
HFF-10-G-610-610-X-DP-DG	E 10	610	610	292	21,00	2000	210
HFF-10-G-305-305-X-DP-DG	H 13	305	305	292	5,25	500	250
HFF-13-G-305-610-X-DP-DG	H 13	305	610	292	10,50	1000	250
HFF-13-G-610-610-X-DP-DG	H 13	610	610	292	21,00	2000	250
HFF-14-G-305-305-X-DP-DG	H 14	305	305	292	5,25	500	270
HFF-14-G-305-610-X-DP-DG	H 14	305	610	292	10,50	1000	270
HFF-14-G-610-610-X-DP-DG	H 14	610	610	292	21,00	2000	270
HFF-10-G-305-305-XL-DP-DG	E 10	305	305	292	6,75	750	210
HFF-10-G-305-610-XL-DP-DG	E 10	305	610	292	13,50	1500	210
HFF-10-G-610-610-XL-DP-DG	E 10	610	610	292	27,00	3000	210
HFF-10-G-305-305-XL-DP-DG	H 13	305	305	292	6,75	750	250
HFF-13-G-305-610-XL-DP-DG	H 13	305	610	292	13,50	1500	250
HFF-13-G-610-610-XL-DP-DG	H 13	610	610	292	27,00	3000	250
HFF-14-G-305-305-XL-DP-DG	H 14	305	305	292	6,75	750	270
HFF-14-G-305-610-XL-DP-DG	H 14	305	610	292	13,50	1500	270
HFF-14-G-610-610-XL-DP-DG	H 14	610	610	292	27,00	3000	270

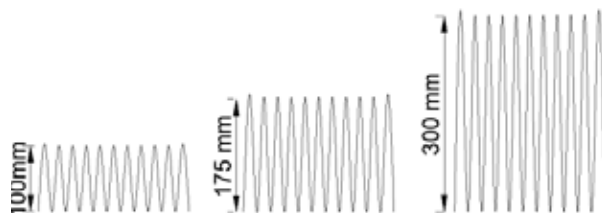
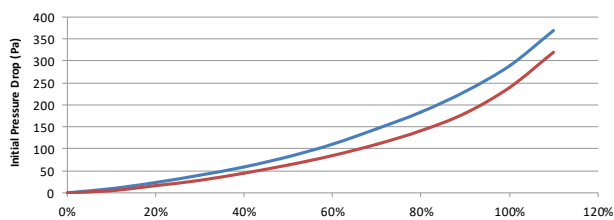

HEPA V COMPACT FILTERS



APPLICATIONS & ADVANTAGES

- ✓ Pre filtration in high air flow systems
- ✓ Final filtration of suspended particles
- ✓ Atmosphere control in hospitals, laboratories, clean rooms, processing data centres
- ✓ Comfort air conditioning applications

HEPA V COMPACT FILTERS



TECHNICAL SPECIFICATIONS

Filter Media : Minipleat Micro Glass Fibre
 Frame Material : Plastic Header Thickness 25mm
 Classification (EN1822) : E10 - U17
 Gasket : Cont. Round Pu / Flat Epdm
 Seperator : Hotmelt
 Sealant : 2K Polyur ethane
 Final Pressure Drop : 600 Pa
 Max. Temperature : 80 °C
 Max. Moisture : 90%



PRODUCT CODE	CLASS EN1822	WIDTH (mm)	HEIGHT (mm)	DEPTH (mm)	FILTRATION AREA (m2)	NOMINAL AIR FLOW (m3/h)	INITIAL PRESSURE DROP (± 10% Pa)
VC-10-287-592-CP	E 10	287	592	292	9,00	1700	170
VC-10-490-592-CP	E 10	490	592	292	15,00	2800	170
VC-10-592-592-CP	E 10	592	592	292	18,00	3400	170
VC-11-287-592-CP	E 11	287	592	292	9,00	1700	190
VC-11-490-592-CP	E 11	490	592	292	15,00	2800	190
VC-11-592-592-CP	E 11	592	592	292	18,00	3400	190
VC-12-287-592-CP	E 12	287	592	292	9,00	1700	210
VC-12-490-592-CP	E 12	490	592	292	15,00	2800	210
VC-12-592-592-CP	E 12	592	592	292	18,00	3400	210
VC-13-287-592-CP	H 13	287	592	292	9,00	1000	250
VC-13-490-592-CP	H 13	490	592	292	15,00	1650	250
VC-13-592-592-CP	H 13	592	592	292	18,00	2000	250

PRODUCT CODE EXPLANATION

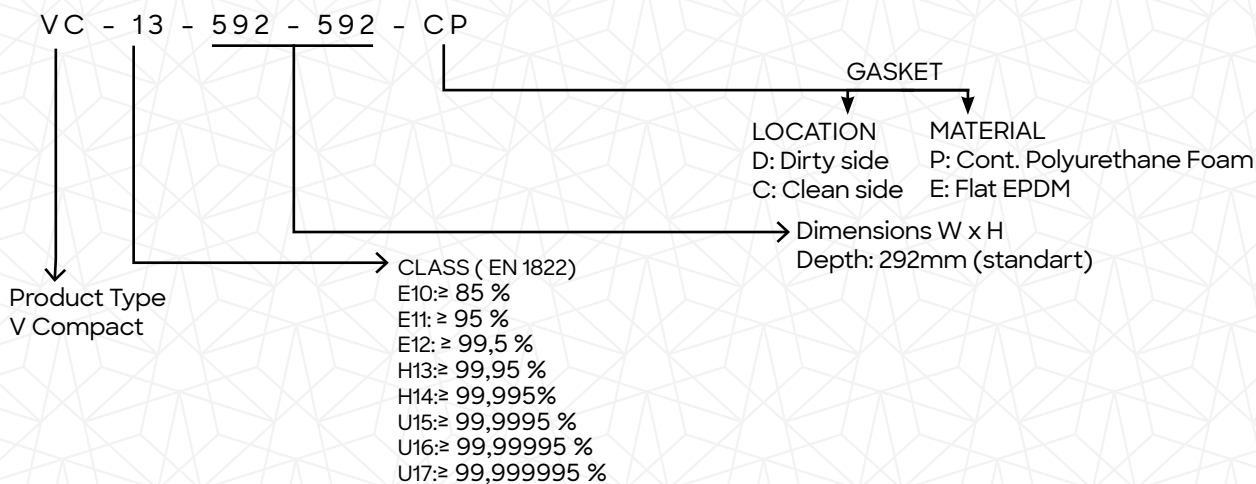

EPA & HEPA & ULPA V BANK FILTERS



APPLICATIONS & ADVANTAGES

- ✓ Lightweight construction
- ✓ High filtration surface
- ✓ Low pressure drop
- ✓ Continuous gasket enables leak free filtration
- ✓ Ventilation and air conditioning in the electronics, pharmaceutical and food industry
- ✓ Particulate control in hospitals, laboratories, clean room processing, data centres
- ✓ Separation of viruses, bacterial, aerosol and toxic dust

PRODUCT CODE EXPLANATION

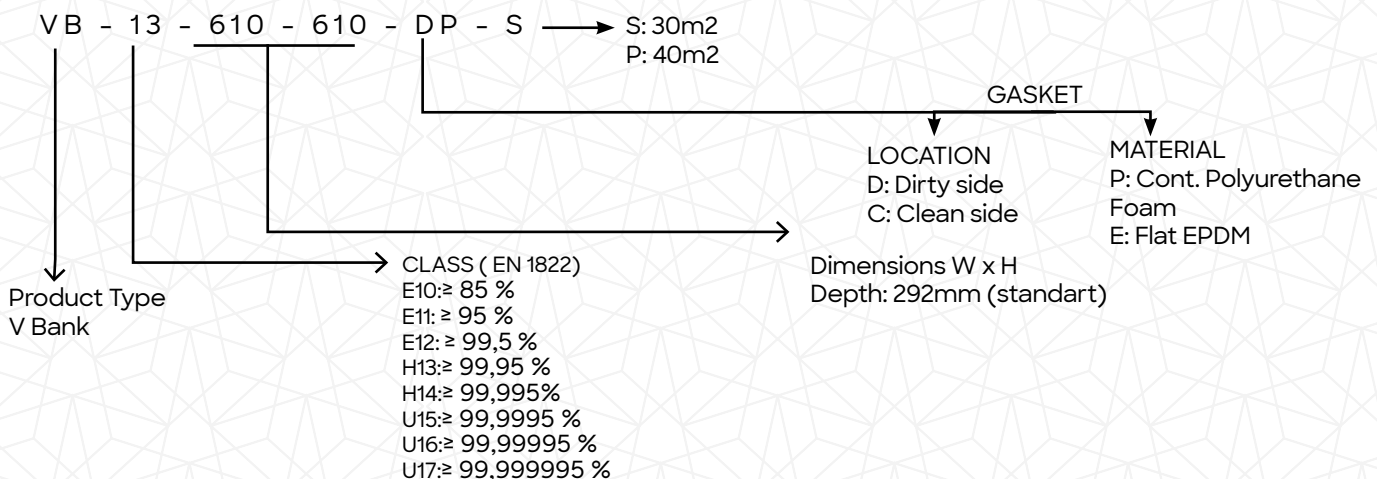

V BANK FILTERS



TECHNICAL SPECIFICATIONS

Filter Media : Minipleat Micro Glass Fibre
 Frame Material : Galvanized Steel
 Classification (EN779) : E10 - U17
 Gasket : Cont. Round Pu / Flat Epdm
 Seperator : Hotmelt
 Sealant : 2K Polyur ethane
 Final Pressure Drop : 600 Pa
 Max. Temperature : 80 °C
 Max. Moisture : 90%



PRODUCT CODE	CLASS EN1822	WIDTH (mm)	HEIGHT (mm)	DEPTH (mm)	FILTRATION AREA (m2)	NOMINAL AIR FLOW (m3/h)	INITIAL PRESSURE DROP (± 10% Pa)
VB-10 - 305-305-DP-S	E 10	305	305	292	7,50	750	180
VB-10 - 305-610-DP-S	E 10	305	610	292	15,00	1500	180
VB-10 - 610-610-DP-S	E 10	610	610	292	30,00	3000	180
VB-13 - 305-305-DP-S	H 13	305	305	292	7,50	750	250
VB-13 - 305-610-DP-S	H 13	305	610	292	15,00	1500	250
VB-13 - 610-610-DP-S	H 13	610	610	292	30,00	3000	250
VB-14 - 305-305-DP-S	H 14	305	305	292	7,50	750	280
VB-14 - 305-610-DP-S	H 14	305	610	292	15,00	1500	280
VB-14 - 610-610-DP-S	H 14	610	610	292	30,00	3000	280
VB-10 - 305-305-DP-P	E 10	305	305	292	10,00	1000	200
VB-10 - 305-610-DP-P	E 10	305	610	292	20,00	2000	200
VB-10 - 610-610-DP-P	E 10	610	610	292	40,00	4000	200
VB-13 - 305-305-DP-P	H 13	305	305	292	10,00	850	280
VB-13 - 305-610-DP-P	H 13	305	610	292	20,00	1700	280
VB-13 - 610-610-DP-P	H 13	610	610	292	40,00	3400	280
VB-14 - 305-305-DP-P	H14	305	305	292	10,00	1000	320
VB-14 - 305-610-DP-P	H14	305	610	292	20,00	2000	320
VB-14 - 610-610-DP-P	H14	610	610	292	40,00	4000	320

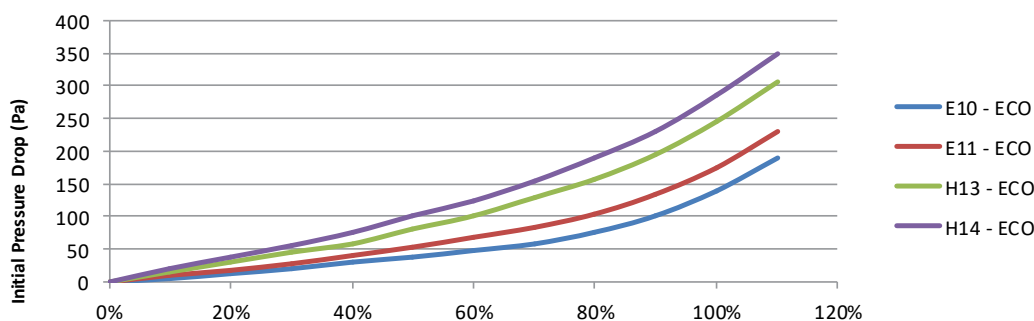

HOODED TYPE FILTERS



APPLICATIONS & ADVANTAGES

- ✓ Lightweight construction
- ✓ High filtration surface
- ✓ Low pressure drop
- ✓ Continuous gasket enables leak free filtration
- ✓ Ventilation and air conditioning in the electronics, pharmaceutical and food industry
- ✓ Particulate control in hospitals, laboratories, clean room processing, data centres
- ✓ Separation of viruses, bacterial, aerosol and toxic dust

PRODUCT CODE EXPLANATION

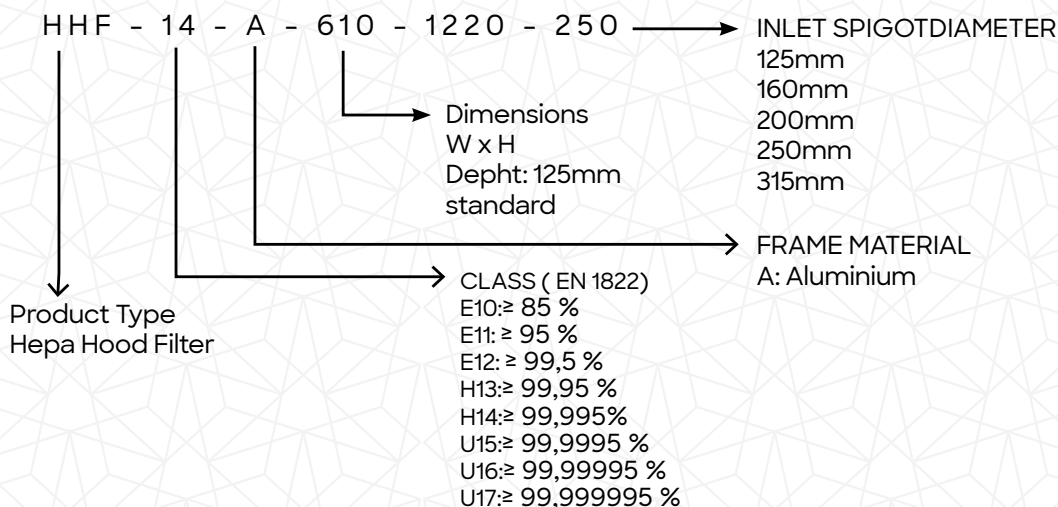

HOODED TYPE FILTERS



TECHNICAL SPECIFICATIONS

Filter Media : Minipleat Micro Glass Fibre
 Frame Material : Extruded Aluminium
 Classification (EN779) : E10 - U17
 Gasket : Optional (Polyurethane / Epdm)
 Seperator : Hotmelt
 Sealant : 2K Polyurethane
 Final Pressure Drop : 600 Pa
 Max. Temperature : 80 °C
 Max. Moisture : 90%



PRODUCT CODE	CLASS EN1822	WIDTH (mm)	HEIGHT (mm)	DEPTH (mm)	SPIG OT DIAMETER (mm)	FILTRATION AREA (m2)	NOMINAL AIR FLOW (m3/h)	INITIAL PRESSURE DROP (± 10% Pa)
HHF-13-A-305-305-Ø125-DG	H 13	305	305	125	Ø125	2,45	150	100
HHF-13-A-305-610-Ø150-DG	H 13	305	610	125	Ø150	4,90	300	100
HHF-13-A-457-457-Ø150-DG	H 13	457	457	125	Ø150	5,50	340	100
HHF-13-A-535-535-Ø200-DG	H 13	535	535	125	Ø200	7,55	465	100
HHF-13-A-575-575-Ø200-DG	H 13	575	575	125	Ø200	8,70	535	100
HHF-13-A-610-610-Ø200-DG	H 13	610	610	125	Ø200	9,80	600	100
HHF-13-A-610-762-Ø250-DG	H 13	610	762	125	Ø250	12,25	750	100
HHF-13-A-610-915-Ø250-DG	H 13	610	915	125	Ø250	14,70	900	100
HHF-13-A-610-1220-Ø250-DG	H 13	610	1220	125	Ø250	19,60	1200	100
HHF-14-A-305-305-Ø125-DG	H 14	305	305	125	Ø125	2,45	150	125
HHF-14-A-305-610-Ø150-DG	H 14	305	610	125	Ø150	4,90	300	125
HHF-14-A-457-457-Ø150-DG	H 14	457	457	125	Ø150	5,50	340	125
HHF-14-A-535-535-Ø200-DG	H 14	535	535	125	Ø200	7,55	465	125
HHF-14-A-575-575-Ø200-DG	H 14	575	575	125	Ø200	8,70	535	125
HHF-14-A-610-610-Ø200-DG	H 14	610	610	125	Ø200	9,80	600	125
HHF-14-A-610-762-Ø250-DG	H 14	610	762	125	Ø250	12,25	750	125
HHF-14-A-610-915-Ø250-DG	H 14	610	915	125	Ø250	14,70	900	125
HHF-14-A-610-1220-Ø250-DG	H 14	610	1220	125	Ø250	19,60	1200	125

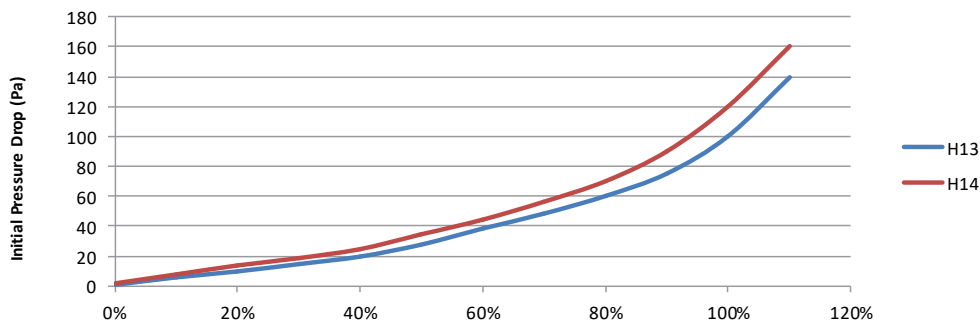



AFT FILTER®



products
gas (odour) filtration



GAS

(ODOUR)

FILTRATION

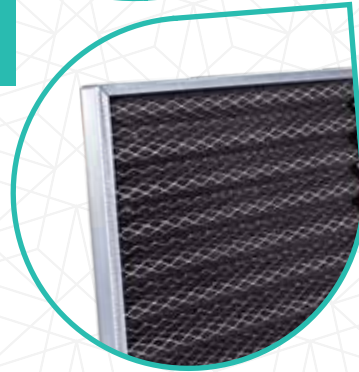

take a breathe

PANEL FILTERS



V COMPACT FILTER



- Z TYPE AC PANEL FILTER
- GRANULAR AC FILLED PANEL FILTER

AC CYLINDER CARTRIDGE FILTERS



- AC CYLINDER CARTRIDGE SET
- AC CYLINDER CARTRIDGE



ACTIVATED CARBON PANEL FILTERS

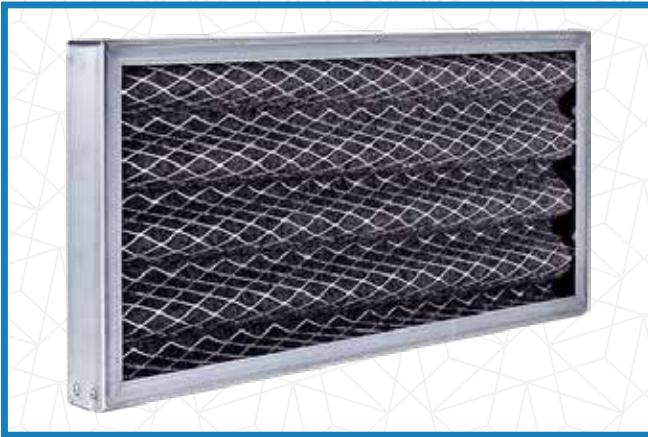

AC Z TYPE PANEL

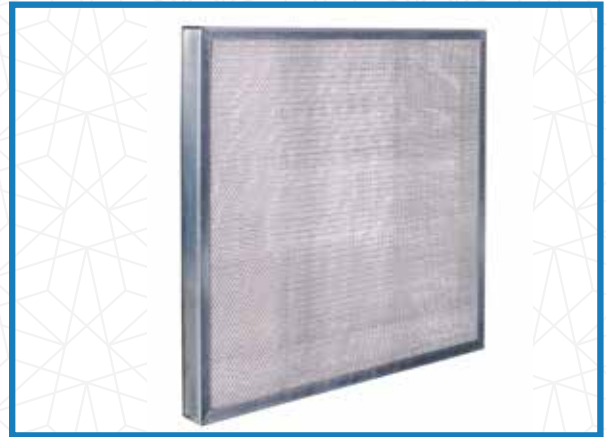

AC GRANULAR FILLED PANEL

APPLICATIONS & ADVANTAGES

- ✓ Absorbs odor and gas in air improvement and air conditioning plants
- ✓ Easy installation
- ✓ Used as prefilter for general ventilation and air conditioning plants with high capacity absorption of especially dry dust and odors

PRODUCT CODE EXPLANATION

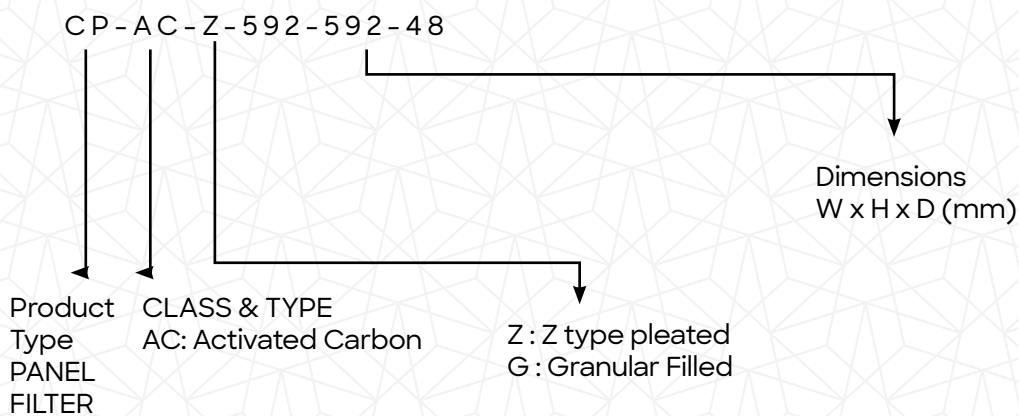

AC Z TYPE PANEL



TECHNICAL SPECIFICATIONS

Filter Media : Activated Carbon Impregnated
 : Synthetic Media
 Frame Material : Galvanized Sheet Metal
 Classification : ePMcoarse/ G3
 Gasket : Optional (Polyurethane / Epdm)
 Final Pressure Drop : 250 Pa
 Max. Temperature : 80 °C
 Max. Moisture : 90% rH



PRODUCT CODE	WIDTH (mm)	HEIGHT (mm)	DEPTH (mm)	FILTRATION AREA (m2)	NOMINAL AIR FLOW (m3/h)	INITIAL PRESSURE DROP (± 10% Pa)
CP-AC-Z-287-287-48	287	287	48	0,15	750	80
CP-AC-Z-287-592-48	287	592	48	0,30	1500	80
CP-AC-Z-490-592-48	490	592	48	0,50	2480	80
CP-AC-Z-592-592-48	592	592	48	0,60	3000	80
CP-AC-Z-287-287-96	287	287	96	0,30	750	50
CP-AC-Z-287-592-96	287	592	96	0,60	1500	50
CP-AC-Z-490-592-96	490	592	96	0,80	2480	50
CP-AC-Z-592-592-96	592	592	96	1,00	3000	50

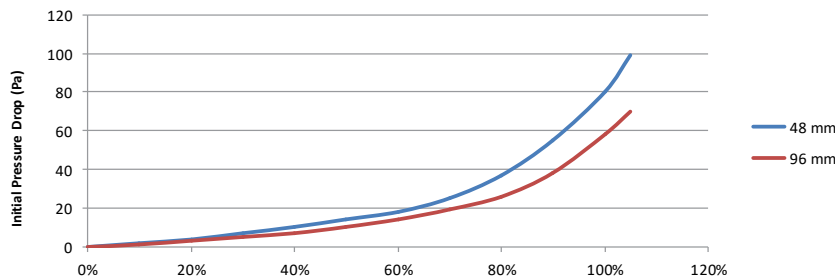

AC GRANULAR FILLED PANEL



TECHNICAL SPECIFICATIONS

Filter Media : Granular Activated Carbon
 Frame Material: : Galvanized Sheet Metal
 Classification (EN 779:2012) : AC
 Classification (ISO 16890) : ePMcoarse
 Gasket : Optional (Polyurethane / Epdm)
 Rate Face Velocity : 2,50 m/s
 Max. Temperature : 50 °C
 Max. Moisture : 70%



PRODUCT CODE	WIDTH (mm)	HEIGHT (mm)	DEPTH (mm)	WEIGHT (KG)	NOMINAL AIR FLOW (m3/h)	INITIAL PRESSURE DROP (± 10% Pa)
CP-AC-G-287-287-24	287	287	24	1,20	150	80
CP-AC-G-287-592-24	287	592	24	2,40	300	80
CP-AC-G-490-592-24	490	592	24	4,00	500	80
CP-AC-G-592-592-24	592	592	24	5,00	600	80
CP-AC-G-287-287-48	287	287	48	2,25	150	140
CP-AC-G-287-592-48	287	592	48	4,50	300	140
CP-AC-G-490-592-48	490	592	48	7,80	500	140
CP-AC-G-592-592-48	592	592	48	9,60	600	140



ACTIVATED CARBON V COMPACT FILTERS



TECHNICAL SPECIFICATIONS

Filter Media	: Activated Carbon Combined with Syntethic Media
Frame Material	: Plastic
Header Thickness	: 25mm
Classification (EN779: 2012)	: AC
Classification (ISO 16890)	: ePMcoarse 2,5
Gasket	: Optional (Polyurethane / Epdm)
Seperator	: Hotmelt
Sealant	: 2K Polyurethane
Final Pressure Drop	: 450 Pa
Max. Temperature	: 80 °C
Max. Moisture	: 90%



PRODUCT CODE	CLASS 799	CLASS ISO 16890	WIDTH (mm)	HEIGHT (mm)	DEPTH (mm)	FILTRATION AREA (m2)	NOMINAL AIR FLOW (m3/h)	INITIAL PRESSURE DROP (± 10% Pa)
VC-AC-287-592	F7	ePM2,5 65%	287	592	292	1700	750	100
VC-AC-490-592	F7	ePM2,5 65%	490	592	292	2800	1500	100
VC-AC-592-592	F7	ePM2,5 65%	592	592	292	3400	2480	100

PRODUCT CODE EXPLANATION

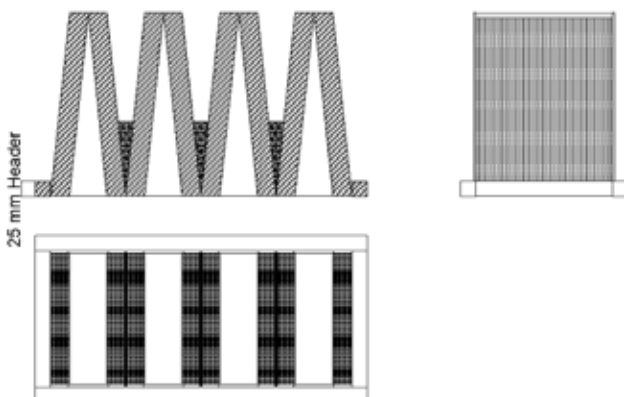
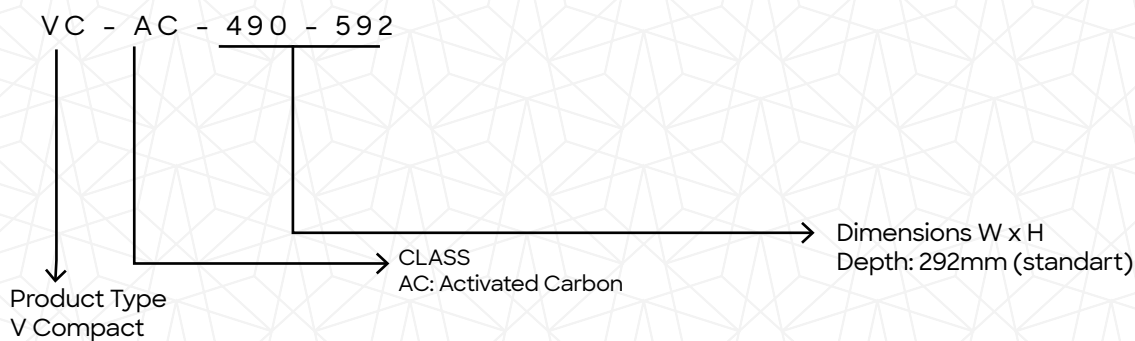

ACTIVATED CARBON CYLINDRICAL CARTRIDGE FILTER



TECHNICAL SPECIFICATIONS

Filter Media	: Pellet Granular Activated Carbon
Frame Material	: Electro Galvanized
Classification (EN779: 2012)	: AC
Final Pressure Drop	: 70 Pa
Max. Temperature	: 40 °C
Max. Moisture	: 70%

ACTIVATED CARBON CYLINDRICAL CARTRIDGE FILTER SET

PRODUCT CODE	WIDTH (mm)	HEIGHT (mm)	DEPTH (mm)	NUMBER OF CARTRIDGE	NOMINAL AIR FLOW (m ³ /h)	INITIAL PRESSURE DROP (± 10% Pa)	WEIGHT (kg)
CCS-305-610-8	305	610	400	8	1700	250	24
CCS-610610-16	610	610	400	16	3400	250	48



ACTIVATED CARBON CYLINDRICAL CARTRIDGE

PRODUCT CODE	DIAMETER (mm)	HEIGHT (mm)	NOMINAL AIR FLOW (m ³ /h)	INITIAL PRESSURE DROP (± 10% Pa)	WEIGHT (kg)
CC-140-400	140	140	215	270	2,5



products

filtration equipments



FILTRATION

EQUIPMENTS



take a breathe



FAN FILTER UNITS



HEPA TERMINAL BOXES FAN FILTER



FILTER FRAMES/HOUSINGS



TECHNICAL SPECIFICATIONS

Material	: Painted DKP Steel
Colour	: RAL 9010 (standard)
Installation Type	: Hang by rods
Diffuser Type	: Perforated Sheet or Swirl Diffuser
Air Intake	: On side / On top
Flange	: Yes

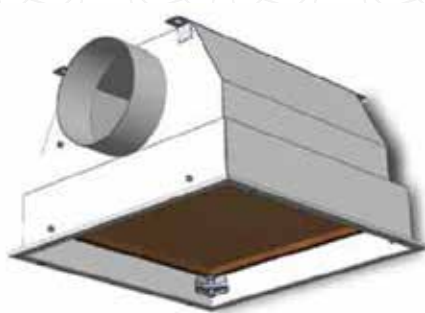

PRODUCT CODE	FILTER DIMENSIONS (H13)				HEPA BOX DIMENSIONS				DIFFUSER DIMENSIONS	
	WIDTH (mm)	LENGTH (mm)	NOMINAL AIR FLOW (m ³ /h)	INITIAL PRESSURE DROP (± 10% Pa)	WIDTH (mm)	LENGTH (mm)	HEIGHT (mm)	COLOR DIAMETER (mm)	WIDTH (mm)	LENGTH (mm)
HTB-305-305-Ø125	305	305	150	100	325	325	300	125	375	375
HTB-457-457-Ø160	457	457	340	100	477	477	320	160	527	527
HTB-535-535-Ø200	535	535	460	100	555	555	360	200	605	605
HTB-575-575-Ø200	575	575	535	100	595	595	360	200	645	645
HTB-610-610-Ø250	610	610	600	100	635	635	400	250	680	680



Hepa Terminal Box is a terminal filtration device in which terminal hepa filters insalled. It consists of a static pressure box, HEPA filter and diffuser.

It is installed at the same level of the ceiling where hepa filter is fixed inside the box to produce the required cleanliness in its specified classification. It creates turbulent flow to ensure a good mixture of dust-free air in the enviroment.

FAN FILTER UNITS

TECHNICAL SPECIFICATIONS

Frame Material	: Aluminium / Painted DKP Steel
Classification of Prefilter	: H14 (EN1822) : G4 (EN779:2012), ePMcoarse (ISO16890)
FAN Type	: EC / AC Plug Fan
AirFlow Controller	: 0-10 V potentiometer (OPTIONAL)
Pressure Sensor	: 0-500 Pa Pressure Gauge (OPTIONAL)
Voltage / Hz	: 230V 50Hz

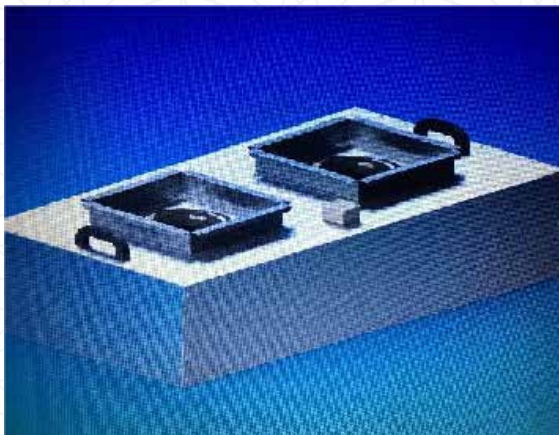

PRODUCT CODE	CLASS EN1822	WIDTH (mm)	LENGHT (mm)	DEPTH (mm)	FILTRATION AREA (m2)	NOMINAL AIR FLOW (m3/h)	INITIAL PRESSURE DROP (± 10% Pa)	SUPPLY POWER 230V AC 50-60Hz	NOISE dB(A)
FFU-14-A-EC-305-305	H 14	305	305	450	2,45	150	125	95 W	58
FFU-14-A-EC-457-457	H 14	457	457	450	5,50	340	125	95 W	62
FFU-14-A-EC-535-535	H 14	535	535	450	7,55	465	125	130 W	62
FFU-14-A-EC-575-575	H 14	575	575	450	8,70	535	125	230 W	64
FFU-14-A-EC-610-610	H 14	610	610	450	9,80	600	125	250 W	68
FFU-14-A-EC-610-915	H 14	610	915	450	15,6	900	125	320 W	68
FFU-14-A-EC-610-1220	H 14	610	1220	450	20,8	1200	125	480	72

HIGH PERFORMANCE FAN FILTER UNIT

H14 filter efficiency 99,995 MMPS

G4- M5 class prefilter to protect H14

Hepa filter

Compact Efficient EC Plug FAN

0,45 m/s laminar air flow

OPTIONAL Variable Speed controller

OPTIONAL Magnehelic Pressure Gauge

Differential Pressure Monitoring DOP Test port .

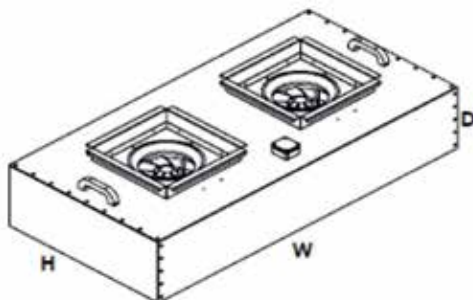

FILTER FRAMES & HOUSINGS

TECHNICAL SPECIFICATIONS

Material: : Galvanised Steel/ Stainless Steel 304
 Suitable For : Pre Filters/ Bag Filters/ V Compact Filters
 Filter Installation : Hinges at corners
 Filter Depth : 25/48

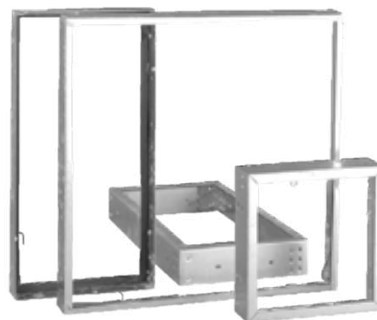

PRODUCT CODE	FRAME SIZE (W x H x D) mm	FILTER SIZE
FH-G-305-305-75	305x305x75	278x287x25/48
FH-G-305-610-75	305x610x75	287x582x25/48
FH-G-508-610-75	508x610x75	490x592x25/48
FH-G-610-610-75	610x610x75	592x592x25/48

PRODUCT CODE	FRAME SIZE (W x H x D) mm	FILTER SIZE
FH-G-305-305-100	305x305x100	278x287x25+48
FH-G-305-610-100	305x610x100	287x582x25+48
FH-G-508-610-100	508x610x100	490x592x25+48
FH-G-610-610-100	610x610x100	592x592x25+48

Designed for installation of prefilters, bag filters or v type compact filters in air handling units. Modular design for different dimensions give easy access for safe filter installation.

Special housings for different depths possible. Also custom design for 292 mm HEPA Filters with “ZERO LEAK GUARANTEE”





AFT FILTER®
take a breathe



Aft filters working on clean air for future & healthier living environments all around the world, Serving high quality products with fast delivery options.

Thanks to our customers for choosing Aft filters. Take a deep breathe.



take a breathe



AFT FILTER®

SARAY MAH . 1022.CAD No:9 Kahramankazan/Ankara

Tel: +90 (312) 815 44 34 - Fax: +90 (312) 815 44 77 info@aftfiltre.com.tr

 | www.aftfiltre.com.tr  | [aftfilters](https://www.facebook.com/aftfilters)  | [aftfilter](https://www.instagram.com/aftfilter)  | [aftfilter](https://www.youtube.com/aftfilter)  | [aftfilter](https://www.linkedin.com/aftfilter)

@redfigurecreative